

# Television

and *SHORT-WAVE WORLD*

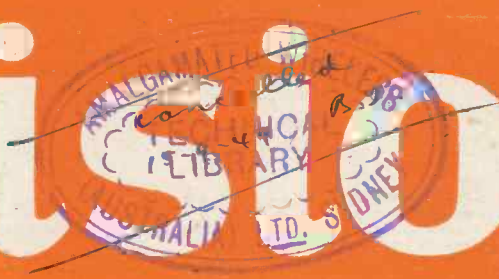

NOVEMBER 1938

No. 129. Vol. XI.

1/-

**REDUCING  
MOTOR-CAR  
INTER-  
FERENCE**

**SIMPLE  
METHOD OF  
INCREASING  
RANGE**

**SHORT  
WAVES**

**25-WATT  
C.W.  
TRANSMITTER**

**CRYSTAL MICROPHONE PRE-AMPLIFIER  
BATTERY-OPERATED TRANSMITTER  
A.V.C. ON SHORT-WAVE RECEIVERS**



**SHORT-WAVE  
TRANSMITTER**  
*with*  
**NEW IDEAS**

**SEE  
PAGE  
693**

BERNARD JONES PUBLICATIONS LTD.  
CHANSITOR HOUSE, CHANCERY LANE  
LONDON W.C.2.

THE FIRST TELEVISION JOURNAL IN THE WORLD





# TELEVISION

## and SHORT-WAVE WORLD

### Special Features

	PAGE
The Television Picture and Interference	653
Simple Television Transmission with a Disc	655
New Miniature Cathode-ray Tubes	658
Mechanical-optical Film Transmitter	659
A Simple Method of Increasing Range	661
A Visit to the Eiffel Tower Television Station	669
How the Picture is Synchronised	671
A 2-channel Pre-amplifier	683
Improving Performance of Communication Receivers	686
A PT7 Battery-operated Transmitter	688
Modern Transmitter Construction	693
R.A.F. C.W.R. Transmitter	702

### TELEVISION AND SHORT-WAVE WORLD

**Proprietors:**  
BERNARD JONES PUBLICATIONS, LTD.

**Editor-in-Chief:**  
BERNARD E. JONES.

**Editor:**  
H. CORBISHLEY, F.T.S.

**Short-Wave Editor:** KENNETH JOWERS

**Editorial, Advertising and Publishing Offices:**

Chansitor House, 38, Chancery Lane, London, W.C.2.

Telephones: Holborn 6158, 6159.

Telegrams: Beejapee, Holb., London.

Subscription Rates: Post paid to any part of the world—3 months, 3/6; 6 months, 7/-; 12 months, 14/-.

Published Monthly—1/- net.  
(On the first day of the month).

Contributions are invited and will be promptly considered. Correspondence should be addressed according to its nature, to the Editor, the Advertisement Manager, or the Publisher, "Television and Short-wave World," Chansitor House, Chancery Lane, London, W.C.2.

#### IMPORTANT

"Television and Short-wave World" is registered at the General Post Office, London, for transmission to Canada and Newfoundland by Magazine Post. Entered as Second-class mail matter, Boston, Mass.

## COMMENT OF THE MONTH

### Television and the Cinema

ON other pages in this issue we publish a lengthy extract from a paper read by Capt. A. G. D. West, M.A., B.Sc., before the British Kinematograph Society. Captain West, in addition to being the President of this Society is, of course, the Technical Director of Baird Television, Ltd., and he is therefore eminently entitled to speak of the probable future link between television and the cinema. His paper, particularly the portion which we publish, is chiefly concerned with the technical aspects of the relation between television and cinematography and it foreshadows a time, perhaps very soon, when the present impasse between cinema interests and the B.B.C. will have to be removed. The means now exist for large-screen television in public halls, and three important cinemas in the West End have been equipped with apparatus capable of projecting a reasonably large television picture on the screen. The apparatus cannot, however, be used for public showing because the B.B.C. owns the copyright of the television transmissions and have vetoed public paid-for reproduction. Clearly there are reasons for this in the case of the reproduction of performances by artists when complicated questions of copyright would arise, but it would not appear to be detrimental to B.B.C. interests to permit events of a topical nature to be reproduced in cinemas.

The benefit that would accrue as a result of such a course would be enormous. Not only would it lead to further intensive development of this class of apparatus and the creation of a large amount of business, but it would also be a means of securing the goodwill of the cinema trade and ultimately removing the ban which it has placed upon the televising of British and American films. In the past television has been regarded by cinema exhibitors as a potential rival but it is becoming apparent now that this opinion is no longer held in any real degree and the trade is prepared to regard it as an ally rather than a rival.

### The New Director General and Television

RECENTLY we had the pleasure of meeting Mr. F. W. Ogilvie, the new B.B.C. Director General. Naturally the subject chiefly discussed was television and it at once became apparent that Mr. Ogilvie has the progress of the new service very much at heart. Even at that early time he had found time to visit Alexandra Palace and make himself acquainted with both the staff and the place. Incidentally he is also a viewer. We certainly gained the impression that Mr. Ogilvie regards the further development of the television service as one of his many duties, and his attitude gives us cause to hope that the days of the service as the Cinderella of broadcasting are now definitely past.

# “BEHIND- THE- SCENES” TELEVISION IN U.S.A.

A VERY definite move to establish television is being made in America and various tests are being made in order to obtain an idea of public reaction. The National Broadcasting Company have set up a behind-the-scenes television studio and already more than 14,000 people have been taken “behind the scenes” in television since its inauguration on September 1. The visitors are given an opportunity not only to view real broadcasts, but to participate themselves during their visit to the studios.

Trained guides take visitors on tour of the television studios, and they report that most people are incredulous when they see the wonders of television unfold before them.

Men are inclined to ask about tech-

anical details. Women are interested in questions of television make-up, etc.

It is a practice on the tours to divide the parties in half, putting one section in the viewing room, equipped with receiving sets, and the other in the television studio, where individuals passing before the camera are televised for the benefit of people in the adjoining room.

The tour in N.B.C.’s television

studio begins in a television museum, where are displayed some of the early television devices. Next stop is the viewing room, where four receivers are working. The tour continues to the visual effects room, fitted with miniature sets used for panoramic shots, and finally to the television studio itself. This studio is equipped with cameras, stage sets and a small, glass-enclosed “theatre” for televising moving dioramas and puppets.

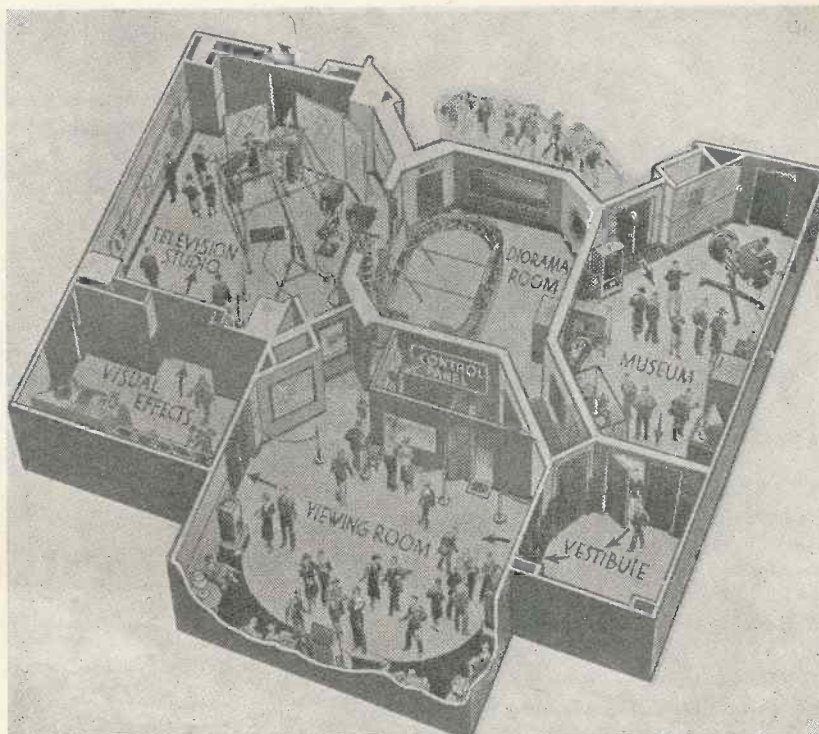

The N.B.C. studio and viewing room set up which is daily visited by large numbers of the American public.

## “SIMPLE TELEVISION TRANSMISSION WITH A DISC.”

(Continued from preceding page)

small synchronous motor. Contrary to standard projector practice, it is unnecessary to provide a drive for the sprocket feeding the film to the gate. Sound scanning with sound films requires no special arrangements for maintaining a perfectly uniform film speed, in view of the continuous film motion employed.

### Synchronising Signals

In addition to the picture signals, frame and line synchronising signals must also be transmitted. The synchronising signals are generated as follows:

A disc is mounted on the shaft of

the synchronous motor which drives the film; it interrupts the beam of light between a lamp and a photoelectric cell, so that only during the time between two pictures does the light pass through a hole in the disc on to the cell. The cell current furnishes a signal which is amplified in the same way as the picture signal.

The line synchronising signal is generated in the same way, using, however, the apertures in the Nipkow disc. Images of the holes are thrown by means of a second optical system on a fixed aperture behind which a secondary electron multiplier is set up. In this way a short rectangular signal is produced. To suppress the line synchronising signals during picture synchronising, a revolving diaphragm is arranged in the path of the beam used for the line synchronising signals.

## “Television & Short-wave World” in U.S.A.

American readers should note that copies of this journal may be obtained from Hotalings News Agency, Times Buildings, 7th Avenue and 42nd Street, New York.

Mr. Wolfe-Murray, former Secretary of the Royal National Mission to Deep Sea Fishermen, has now officially taken up his position at the Alexandra Palace as B.B.C. television’s first Public Relations Officer.



# NEW MINIATURE CATHODE-RAY TUBES

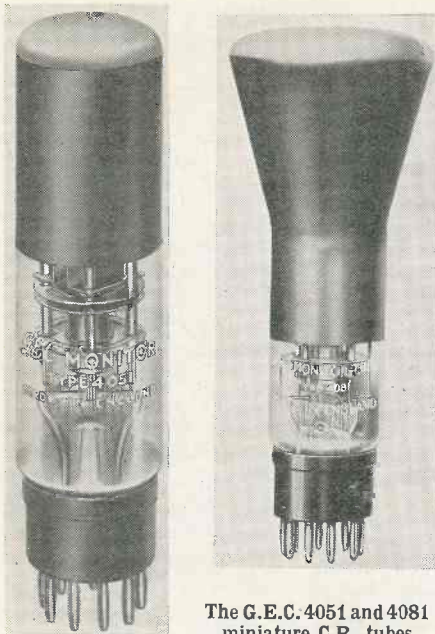

The G.E.C. 4051 and 4081 miniature C.R. tubes.

**S**MALL cathode-ray tubes are being used to an ever-increasing extent for measurement and observation purposes covering an extensive field.

It is natural that with increased demand greater attention has been given to their development which has resulted in marked improvements in their characteristics. This is shown clearly by the characteristics of two new monitor tubes, as they are termed, produced by the General Electric Co., Ltd. The types bear the numbers 4051 and 4081, and they can both be employed for all purposes in which a visual means of studying transient or recurrent operations is required.

Important features of these new tubes are their small physical size and comparatively low operating voltage,

as indicated by the characteristics set out below. In both types separate connections are provided for the four deflector plates so that push-pull scan can be incorporated if desired. The screen is of the medium persistence type having green fluorescence. The base is a nine-pin type (to British standard pin spacing and dimensions).

The characteristics of the type 4051 are:—

- Heater voltage, 4.0 volts.
- Heater current, 0.8 amp.
- Accelerator (anode No. 2) voltage, 250 to 500 volts max.
- Focusing electrode (anode No. 1), 50 to 100 volts.
- Control electrode (modulator), 0 to -20 volts.
- Deflection sensitivity:
  - Plates next accelerator (signal plates: Y<sub>1</sub>, Y<sub>2</sub>),  $\frac{82 \text{ mm. per volt.}}{V}$
  - Plates next screen (time base X<sub>1</sub>, X<sub>2</sub>),  $\frac{73 \text{ mm. per volt.}}{V}$

Where V = voltage on accelerator (anode No. 2).

#### Interelectrode Capacities.

- Modulator to all other electrodes, 25 micro-mfds. approx.
- Between Y plates (plates nearest accelerator: other electrodes earthed), 4 micro-mfds. approx.
- One Y plate to all other electrodes, 13 micro-mfds. approx.
- Between X plates (plates nearest screen: other electrodes earthed), 2 micro-mfds. approx.

One X plate to all other electrodes, 13 micro-mfds. approx.

#### Dimensions.

Maximum overall length, 160 mm. Screen diameter, 39 mm.  $1\frac{1}{2}$  in. approx.).

The price of type 4051 is 45s.

The characteristics of the type 4081 are:—

- Heater voltage, 4.0 volts.
- Heater current, 0.8 amp.
- Accelerator voltage (A<sub>2</sub>), 400 to 800 volts max.
- Focusing electrode (A<sub>1</sub>), 80 to 200 volts max.
- Control electrode (M), 0 to -40 volts.

#### Deflection Sensitivity:

Plates nearest to A <sub>2</sub> : Y <sub>1</sub> , Y <sub>2</sub> ,	155
mm. per volt.	V
Plates nearest to screen: X <sub>1</sub> , X <sub>2</sub>	145
mm. per volt.	V

Where V = voltage on A<sub>2</sub>.

#### Interelectrode Capacities.

- Modulator to all other electrodes, 25 micro-mfds. approx.
- One Y plate to all other electrodes, 13 micro-mfds. approx.
- Y<sub>1</sub> to Y<sub>2</sub> (other electrodes earthed), 3 micro-mfds. approx.
- One X plate to all other electrodes, 13 micro-mfds. approx.
- X<sub>1</sub> to X<sub>2</sub> (other electrodes earthed), 3 micro-mfds. approx.

#### Dimensions.

Maximum overall length, 190 mm. Maximum diameter, 70 mm.

The price of type 4081 is 55s.

## A New H.F. Cable

A novel type of high-frequency cable has been developed by Etablissements Elma of 17, Rue Theophr-Renaudot, Paris. As will be seen from the illustration, the cable consists of a central flexible conductor on which are threaded moulded trolitul thimbles, so shaped that they fit partially one within the other, and permit of a considerable amount of flexibility. There is an exterior

covering of braided wire which provides the outer conductor and also keeps the trolitul thimbles in position. The cable is made in four dia-

meters, viz., 5, 8, 12 and 20 millimetres and the capacities in micro-microfarads are 40, 30, 25 and 20 per metre respectively.

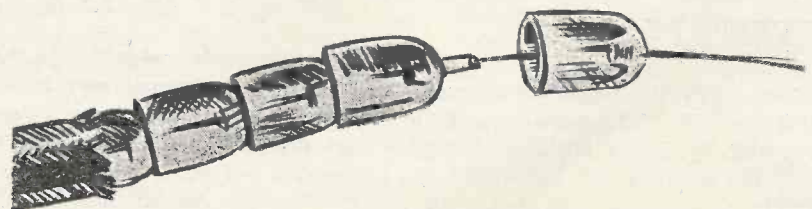

Sketch showing construction of the Elma H.F. cable.

# A MECHANICAL- OPTICAL FILM TRANSMITTER

## DETAILS OF THE NEW SCOPHONY APPARATUS WHICH IS ADAPTABLE FOR DIFFERENT STANDARDS

It is generally recognised that the system of film transmission at present employed at Alexandra Palace does not yield results which equal the direct transmissions. This is due to certain inherent defects in the system which have not been overcome and many authorities contend that better results could be obtained by the use of mechanical-optical principles instead of electronic as at present used.

Scophony, Ltd., have produced a mechanical-optical transmitter which in laboratory demonstrations has provided very fine pictures from film. It uses small and rigid revolving masses and provides a high light efficiency with full definition.

### Optical System

The photographs show the details of the mechanical-optical apparatus and the complete transmitting equipment. An image of an illuminated aperture is formed on the film by a sphero-cylindrical optical system via two revolving polygons mounted at right angles to each other, one revolving slowly forming the vertical scan in conjunction with the film moving continuously in the opposite direction. This moving spot is picked up by another sphero-cylindrical lens system and reproduced as a stationary image on the cathode of an electron multiplier cell, the variations of intensity of the spot as it traverses the film giving rise to variations in output of the cell, so transforming every small section of the picture into an electrical impulse.

The transmitter can be adapted quite easily for different requirements. For instance, sequential scanning is obtained by choosing a line frequency which is an integral multiple of the frame scanning frequency. If

The Scophony mechanical-optical film transmitter.

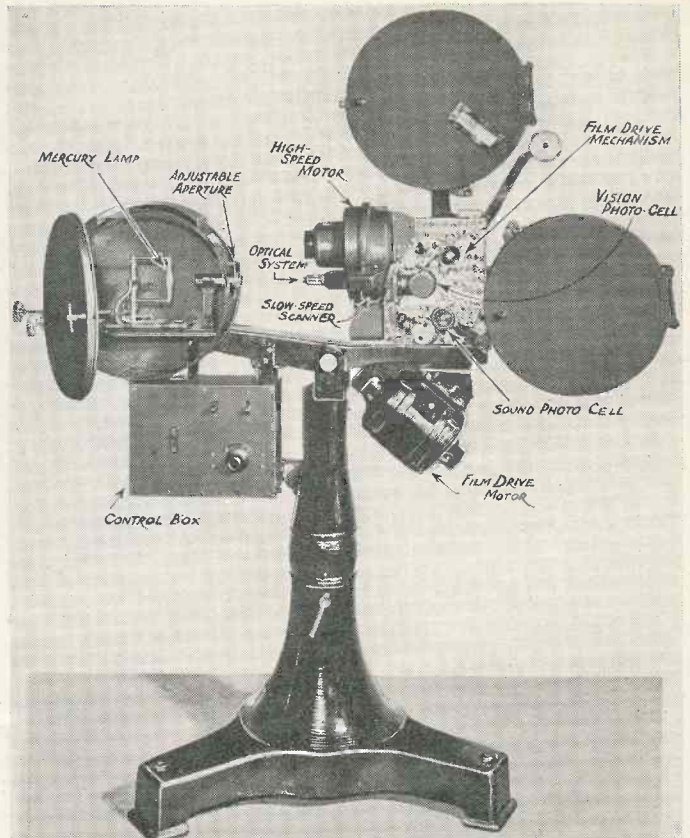

the line frequency is an odd multiple of half the frame scan frequency the resultant picture is an interlaced one. The line frequency is governed by the synchronising generator. The frame frequency is 50 when the slow speed scanner is running and 25 when stationary. Assuming 50-cycle supply frequency, the transmitter can be used for interlaced or sequential scanning with 50 or 25 frames per second.

By using a different gate the transmitter can be adapted to scan the film according to the U.S. standard, i.e., 60 frames from 24 pictures per second.

The source aperture is rectangular and of adjustable dimensions. Thus all types of spurious images (such as "beading") caused by the aperture can be completely eliminated. Spurious images may arise from the amplitude of vertical scan being not exactly equal to the film pitch. Films in general shrink with age. A continuously variable adjustment is provided to compensate for this.

### The High-speed Scanner

(The high speed scanner motor is driven by a specially designed valve

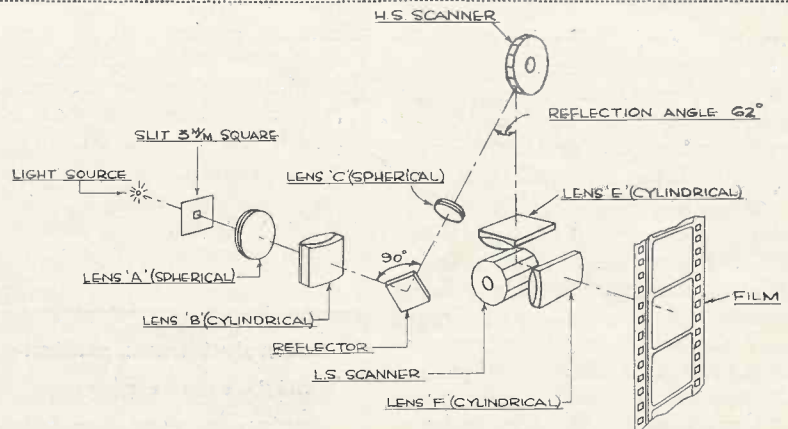

Schematic diagram of the optical system used in Scophony film transmitter.



amplifier from the line frequency supplied in sinusoidal form from the synchronising generator. The motor consists essentially of a phonic wheel tuned to resonate at line frequency. This is connected direct in the anode circuit of a pair of 60-watt valves in parallel operated in the class C condition. Direct current is also passed through the windings of the phonic wheel so as to prevent reversal of the magnetising flux. A subsidiary motor is mounted on the spindle to run the motor into synchronism.

**Performance**

The spot definition is such that an 800 line picture could easily be obtained by reducing the aperture and increasing the scanner speed. The focus of the spot is maintained up to the four edges of the gate and the illumination is uniform. In the model designed for the B.B.C. standard, a film containing vertical lines with a spacing corresponding to 600 elements can be resolved perfectly. The quantity of light incident on the photo-cell is approximately 0.0005 lumen. The photo-cell is of a multi-

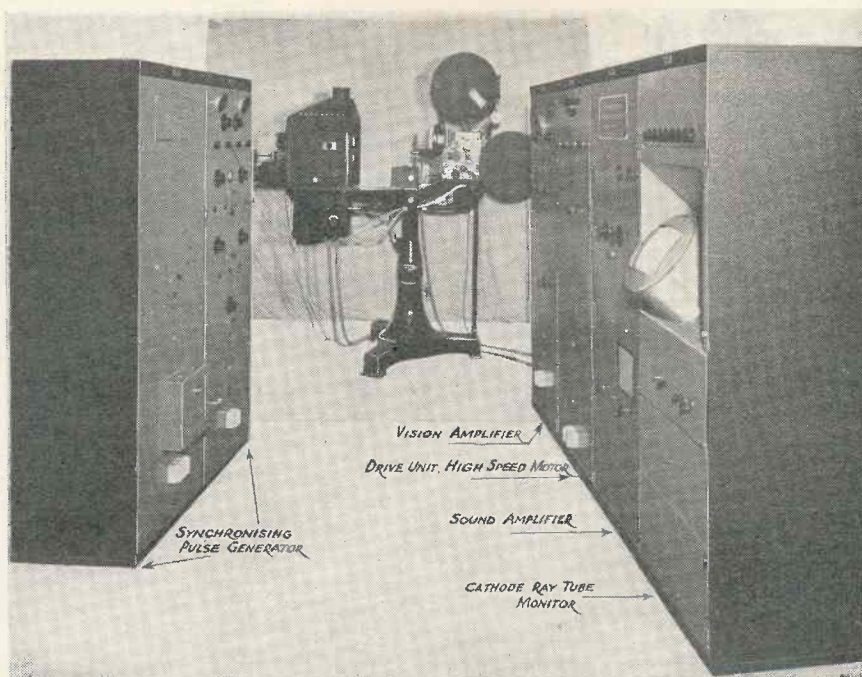

The complete Scophony mechanical-optical film transmitting apparatus.

plier type yielding approximately 0.01 volt picture current for the amplifier. The amplifier is of conventional design with flat frequency response from 0 to 2.5 m.c. but can be made to suit special requirements.

**A TELEVISION QUESTIONNAIRE**

**Some American Ideas**

A TELEVISION questionnaire was recently sent out to radio retailers in the United States in order to ascertain the views of the trade on the effect the introduction of a television service is likely to have on the radio industry.

One question was: "Is the advance television publicity helping or harming business?"

Nearly half of the replies (45.6 per cent.) said it was retarding sales, while 3 per cent. stated that it was helping to sell radio sets now. The largest number (51.4 per cent.) stated that it had little or no effect on present business.

The response to the query as to whether the actual arrival of commercial television would help or harm business was more along expected lines. No less than 72 per cent. of the trade thought that the actual advent of television would cause a boom in radio, while 15.6 per cent. believed that it would be of little, if any,

advantage to the trade. Only 12.4 per cent. thought that it would retard the radio business.

Prices at which television sets should sell well to the public, while allowing a reasonable profit, were from £5 to £100. These prices were arbitrarily divided into three groups. 34.5 per cent. of the replies put a maximum price of £20 on a good television receiver; 55.2 per cent. priced television receivers between £20 and £40, while the remaining 10.3 per cent. figured that a good set could not be sold under £40.

All answers indicated that pictures must be bright, clear, detailed, and free from flicker. The size believed adequate ranged from 4 in. by 4 in.

to 3 ft. by 4 ft. The following tabulation shows the voting on picture size.

5 by 7 in. or less .....	6.5%
5 by 7 in. to 8 by 10 in. ...	36.5%
8 by 10 in. to 11 by 14 in. ...	24.2%
11 by 14 in. to 18 by 24 in. ...	26.2%
18 by 24 in. to 36 by 48 in. ...	6.6%

It would appear that a picture about 11 in. by 14 in., good in every respect, and produced by a receiver selling at £20 is the trade's ideal of television.

**Potentiometers for Television Receivers.**

Potentiometers used in television receivers have to be of the highest quality and at the same time be suitable for use in circuits where high voltages are employed. Reliance units have been designed to withstand voltages in excess of 4,000 between spindle and case.

They are to extend their range of products and have just moved into a new factory at Sutherland Road, Higham Hill, Walthamstow, E.17. In addition to variable resistances for radio and television work they have their own hydraulic plant for bakelite products. Full information regarding Reliance products can be obtained from the above address.

Mention of "Television and Short-wave World" when corresponding with advertisers will ensure prompt attention.



# Scannings and Reflections

## CYRANO DE BERGERAC ON NOVEMBER 4

**L**ESLIE BANKS is to make his first appearance in television in the name part of "Cyrano de Bergerac," which will be performed in the Alexandra Palace studios on November 4. Constance Cummings will play the part of Roxane.

George More O'Farrall, who is producing this famous play by Edmond Rostand, will take advantage for the first time of the new studio equipment to use two studios simultaneously, and the production will be on a correspondingly large scale. Three control rooms will be in operation and eight camera channels—double the number yet used in television. Use is being made of the script specially prepared by the late Robert Loraine, whose superb acting in the rôle of Cyrano will not soon be forgotten. Incidental and ballad music by Jean Nougues will be played by the Television Orchestra, conducted by Hyam Greenbaum.

"Cyrano de Bergerac" tells the story of that gloriously gallant, "nose conscious" figure who, despite his cruel affliction, carries his "Panache"—the spirit of bravery, the wit of courage, the humour of heroism. Feared by all his adversaries in war, he is doomed to unhappiness in his love of the beautiful Roxane who loves the young Baron Christian de Neuvillette.

## THE TELEVISION CABLE

Post Office engineers have now laid the special multi-channel cable as far as Northallerton via Birmingham, Leeds and Manchester. This cable, which has been laid to handle up to 400 telephone conversations simultaneously, may still be suitable for relaying television, if some of the difficulties can be overcome. Although the cable is capable of handling a wide band of frequencies used in television transmission, the main difficulty appears to be phase reversal along the cable. If this can be overcome, then there may be a possibility of television programmes in the North of England.

## B.B.C. TECHNICAL TALKS

It is interesting to note that the B.B.C. are giving technical talks on how to make the most of a television receiver. The first of these talks was on October 24 by T. H. Bridgewater, the Senior Maintenance Engineer at Alexandra Palace. The second talk is scheduled for November 7. It is hoped that these talks, which will deal mainly with operating the television receiver, will enable viewers to know exactly how to make the most of their receivers. It is rather interesting that the television section should be the first to sponsor these technical talks, for discussion under similar lines, but dealing with radio sets, have not been broadcast for a great number of years.

## ULTRA SHORT-WAVE ACTIVITIES

Although it was anticipated that conditions on short and ultra-short waves would deteriorate this year, surprising results are being experienced on 28 mc. Amateurs are finding that even with extremely low power they are able to maintain very long-distance contacts during the day. Signals from Australia and in particular California are being picked up in this country at a strength equal to that of local stations.

It must be admitted, however, that this waveband is erratic and that late in the afternoon it fades out extremely rapidly. However, at the moment, conditions are good between 10 a.m. and 4 p.m., while on occasions, stations can be heard during the early evening. It is hoped that the 10-metre band will remain open during the winter, in order to take the place of the now unreliable 20-metre band.

There is also a report that signals on 5 metres are being heard fairly regularly in California from Australia, and if this should be so, it may be possible for European amateurs to make contact in both directions with America. Although to date, two-way contacts have not been possible between Europe and America, several British amateurs are erecting special equipment in order to make a special

endeavour to make two-way contacts before present conditions disappear.

## TELEVISION FROM EARLS COURT

On two occasions viewers were able to see what was going on at the motor show at Earls Court. The lighting, however, was rather poor and on the second day when motor car accessories were televised, it was rather difficult fully to appreciate some of the finer points dealt with by the commentator. When conditions for transmission are not too favourable it would be better to inform viewers so that they would not doubt the efficiency of their receivers.

The outside broadcasting vans were televised from Alexandra Palace and it was practically impossible to see very much of what was going on inside the vans owing to lack of light. Viewers seeing television for the first time would gain rather a bad impression, which could easily be removed by a short announcement mentioning the fact that the transmission was being made under difficulties.

## TELEVISION SCREENS IN CINEMAS

Capt. A. G. D. West (Baird Television, Ltd.) in his Presidential Address to the British Cinematograph Society, prophesied that before very long television pictures of current events would be seen on full-size screens in every cinema. It is hoped that television will not be considered a competitor but rather an aid to the cinema for it will be of the greatest advantage to be able to see events as they occur. Cinema goers in and around London are able to see the latest newsreel sometimes only two or three hours after the important event, but the smaller cinemas in the provinces are by no means so well-served, and in some of the larger country towns newsreels are often seven days late. This could be overcome by the use of television in the way suggested by Capt. West.

## THE GROWTH OF AMATEUR BROADCASTING

It is pleasant news to hear that there are now well over 5,000 trans-



## MORE SCANNINGS

mitting licences in existence in this country. These licences are, of course, all issued by a special branch of the Post Office and include in addition to amateur licences, special permits to manufacturers and Army, Navy and Air Force Reserves. However, the fact that the number has doubled in the last two or three years, has no doubt influenced component and valve and set manufacturers to take considerably more interest in the requirements of short-wave amateur experimenters. At the present time, amateurs are being well looked after and can obtain their specialised components and equipment at quite a reasonable cost. The manufacturers have also realised that amateurs can utilise the equipment which is being made specially for government services, so that the market is by no means as limited as was at first expected.

### AMERICAN TELEVISION

It would be interesting to find out whether or not transmissions from the new Columbia Television station can be received in Europe. This new transmitter, located in New York, will have the call letters W2XAX. The power input will be 300 kilowatts, a phenomenal figure for an ultra-high frequency station, and to ensure maximum efficiency during the winter the aerials are to be heated from the inside and thermostatically controlled.

As the British television transmissions have been received by R.C.A. in New York, there is every possi-

bility of British experimenters, especially those with beam receiving aerials, being able to pick up at least the sound portion from the new Columbia station.

### BAIRD COLOUR EQUIPMENT

Mr. J. L. Baird has presented to the Science Museum, South Kensington, part of the original colour equipment including the mirror drum which revolves at 6,000 revolutions per minute and has twenty mirrors, together with the colour filter disc. Both of these were used at his demonstrations of colour television at the Dominion Theatre.

Most of Mr. Baird's early equipment can now be seen at the Science Museum.

### NEW TELEVISION SYSTEM

A new system of television transmission is being experimented with at Morecambe Bay to a point nine miles away at Overton. This new system is based on vision rays and has nothing to do with the normal electrical wave. A picture has been received and special towers are being erected at the two points mentioned. It is hoped that before very long complete information on this new scheme will be available.

### TELEVISION "WAR EYE"

American technical experts are of the opinion that television will be of immense value in time of war. It is stated that television cameras could be fitted in aeroplanes and balloons and on high vantage points so that

pictures could be transmitted of enemy territory to the staff headquarters several miles behind the actual front line. There would, of course, be enormous difficulties, but it is claimed that these could be overcome.

### NEWS BY TELEVISION

Those who saw the return of Mr. Chamberlain to Heston Airport, the motor car racing at the Crystal Palace and similar events of general interest, agree that this is the type of programme that will make television popular. News films are also excellent entertainment, particularly when they are changed frequently. Viewers who are rather outside the normal service area and live in country places find that they can obtain considerably more news via television than from the normal small cinemas. It is hoped that this aspect of television entertainment will be carefully considered by the B.B.C. and augmented as far as possible.

### THE ARMISTICE SERVICE

It is expected that the Armistice Day service from Whitehall will make an excellent television transmission, particularly if the cameras are erected to good advantage. There are one or two Government buildings close handy in which the cameras can be placed and it is felt that a record number of viewers will be obtained on that day.

### A RELAY FROM NORTH WEALD AERODROME

The cameramen concerned deserve considerable credit for their work in televising the fast type of planes from the North Weald aerodrome. They had very great difficulty in following some of the faster planes travelling at well over 400 miles per hour, but viewers were able to gain a very good idea as to the life in an up-to-date aerodrome. Many viewers noticed that ghost planes followed the televised planes, and this, it is stated, was due to interference from the electrical systems in the planes actually being televised.

### TELEVISION IN THE PROVINCES

On many occasions it has been claimed that television will soon be an established fact in the provinces. Potential viewers in Birmingham in



Lord Nuffield being televised at the Motor Show at Earls Court.



# DO YOU REALISE HOW GOOD TELEVISION RECEPTION IS TO-DAY, ESPECIALLY BAIRD TELEVISION

## PROVE THIS BY ASKING FOR A DEMONSTRATION OF THE NEW BAIRD MODELS

As the world pioneers of television, Baird Television Ltd., have been in the forefront of progress with every important development in television. Not the least of these is receiver design, for the very first set to show a real television picture was demonstrated by Baird in 1926. With new and up-to-date factory accommodation the company's technical resources have been

**BAIRD**  
**THE NAME SYNONYMOUS WITH TELEVISION**

widened and unequalled research facilities provided. This has culminated in the development of the finest television receivers for domestic receiving purposes. The new range of models has been graded to meet the varying needs of a rapidly expanding viewing public and each set is the best in its class that television has to offer to-day. See them in operation at the leading radio dealers —names and addresses furnished on request to Dept. P.

*Send for New 16 Page Catalogue*

# BAIRD TELEVISION LTD.

Lower Sydenham, London, S.E.26

Telephone: HITHER GREEN 4600.

Telegrams: TELEVISOR, FOREST, LONDON.



**AND MORE REFLECTIONS**

particular have had their hopes raised time after time. There does, however, seem to be a general changing idea that before very long attempts will be made to erect a second television transmitter. An alternative scheme to using the special low-loss cable has been discovered by Post Office engineers. They find that they can cover long distances by a combination of microwave transmitters plus co-axial cable.

It has been realised that there is probably a greater market for television receivers in the provinces than in the London area where there is a wealth of entertainment.

**AMERICAN TELEVISION AGAIN**

A limited television service to the public has just been announced by the Radio Corporation of America. This service will only last for about two hours each week. This is not due to technical difficulties but due to the fact that television, as with ordinary radio in America, must be self-supporting, so until they are sure of a large number of viewers, programmes cannot be sponsored and revenue obtained.

**SALES OF BATTERY SETS**

During the past few weeks there has been an extraordinary increase in the number of battery-operated receivers sold. These sets generally have been of the ordinary broadcast type using three or four valves and costing between £5 and £8. It is stated that the receivers have been bought by listeners who need an alternative source of reception in case of emergency. Listeners know that should there be a break in the power supply service that they are completely cut off from radio reception. An accumulator can, however, be kept on hand and in addition a dry battery will have a fairly long life, despite the fact that they deteriorate if not used.

**A NEW ANNOUNCER**

Listeners to the London Regional programmes will have probably realised by now that they have a new announcer. He is David Hoffman whose face and voice are both very well known to viewers. David Hoffman succeeded Leslie Mitchell as the only male announcer from Alexandra Palace. He is thirty years of age and was at one time announcer with the Canadian broadcasting system.

**B.B.C. FILM TELEVISION**

The B.B.C. are continuing their policy of broadcasting full-length films, When this scheme was originally mooted viewers were rather sceptical as the film transmissions from Alexandra Palace have not been all that they might be. However, there has been a distinct improvement recently and now films have an excellent entertainment value.

Anton Wallbrook, in the "Student of Prague," and Maurice Chevalier

Following the speech an all-star cabaret will be televised, with Gracie Fields, Jean Colin, Oliver Wakefield and Douglas Byng.

This will be Gracie Fields' second visit to the Alexandra Palace studios. Alexandra Palace itself, however, is familiar ground, for it was in the old Alexandra Palace theatre that Gracie Fields scored her first successes in the Archie Pitt shows, "Mr. Tower of London," "Too Many Cooks," and "Safety First."

**TELEVISION AT THE "STAR"**

Great interest has been taken lately in pictures at the Star and Garter Home. In response to an appeal launched by Eileen Ashcroft in the *Daily Mirror*, for television sets in homes such as this, several sets have already been received—one the day after the appeal was made—and nearly £1,000 has been subscribed. One set was presented by the Gaumont-British News Film Company in co-operation with the Baird Television Company.

**TELEVISION'S O.B. AERIAL**

During the recent transmissions, the viewer was shown the aerial used for outside broadcasts. This aerial is fitted to the end of an extension ladder of the type originally used by fire brigades. It can be extended to its maximum height in under four minutes as compared with two or three hours taken in erecting an aerial on top of a mast. This aerial also has the advantage that it can be rotated quite quickly in order to obtain radiation in the right direction. Incidentally the motor on which this ladder is mounted was first put into service in 1916 and it is not very likely, therefore, that the manufacturers had any idea of the ultimate destination of this fire escape.

**TELEVISION DRAMA**

A big television drama "push" is also contemplated, but there is a deplorable paucity of original material and of plays written specially for the medium. Reginald Berkeley's famous "White Chateau," which has been broadcast many times, is on the list. An interesting point about this production is that the grounds of Alexandra Park will be used for one of the sets. It is more than probable that a Territorial unit will take part and bring along a six-inch gun.

**FORTHCOMING TELEVISION PROGRAMMES**

- |      | A—Afternoon.   | E—Evening. |
|------|--|------------|
| Oct. |  |            |
| 31   | <b>SMOKY CELL</b> , an Edgar Wallace thriller (A).   |            |
| Nov. |  |            |
| 1    | <b>THE LAST VOYAGE OF CAPT. GRANT</b> , a new form of television presentation, by Denis Johnston (E).  |            |
| 2    | <b>FIRST AFTER-DINNER SPEECH BY TELEVISION</b> : Mr. J. B. Priestley at Alexandra Palace addresses Festival Dinner of the Royal Photographic Society in London. <b>ALL-STAR CABARET</b> with Gracie Fields, Douglas Byng, Oliver Wakefield and Jean Colin (E). |            |
| 3    | <b>CAST UP BY THE SEA</b> , a Stephen Leacock burlesque (A).   |            |
| 4    | Feature Film: <b>SO ENDED A GREAT LOVE</b> (E).  |            |
| 5    | <b>ICE HOCKEY and CABARET</b> , from Earl's Court (E).   |            |
| 6    | <b>THEATRE PARADE</b> (E).   |            |
| 9    | <b>LORD MAYOR'S SHOW</b> .   |            |
| 10   | <b>EASTERN CABARET</b> (E).  |            |
| 11   | <b>CENOTAPH CEREMONY</b> . Special production of Reginald Berkeley's "The White Chateau" (E).  |            |
| 13   | <b>THE "WHITE CHATEAU"</b> (repeat performance)  |            |
| 15   | <b>RE-VIEW</b> : songs and sketches from the old revues. (E).  |            |
| 16   | <b>WEST END CABARET</b> (A).   |            |
| 18   | <b>GALLOWS GLORIOUS</b> : a play by Ronald Gower (A).  |            |

in the sensational French production "La Kermisse Heroique" were particularly good productions.

**AFTER-DINNER SPEECHES BY TELEVISION**

Mr. J. B. Priestley, the novelist, will give the first after-dinner speech by television on November 2 on the occasion of the Festival Dinner of the Royal Photographic Society at the Dorchester Hotel, presided over by the Duke of Kent. Immediately after the dinner, Mr. Priestley will go to Alexandra Palace and will speak for ten minutes before the television camera. Receivers installed at the Dorchester will enable the guests to see and hear the speaker.



# COLUMBIA BEGINS INSTALLATION OF 300- KILOWATT TRANSMITTER

**A**FTER a year's exhaustive tests, both of the transmitter and of a new type of television antenna for distributing the signal evenly over the entire city and its suburbs, Columbia engineers have begun the work of installing the 100,000-lb. equipment on the 72nd and 73rd floors of the Chrysler Tower in New York. The transmitter will broadcast a high-definition picture signal as powerful as that of any transmitter now in operation.

Arrangements also have been made for a coaxial cable connecting the transmitter with the C.B.S. television studios in the Grand Central Terminal Building nearby.

The installation is to be completed early in 1939, but as additional time will be required for final tests, no date has been decided upon when the first programmes will be put out. When the new station goes on the air next year, it will be the climax of nearly ten years of television experiment by Columbia which, in 1931, broadcast the first regular schedule of television programmes in America when 60-line transmissions were put out. The new station will send out pictures of 441-line definition.

The new C.B.S. television transmitter has been built at a cost of approximately \$500,000 and it is estimated that it will cost another \$150,000 to instal. From the Chrysler Tower, which was picked as the ideal location after careful study of the whole New York skyline, the station will provide primary coverage within a radius of about 40 miles over a total area of about 4,800 square miles.

## A New Aerial

A new type of antenna system, designed under the direction of Dr. Peter C. Goldmark, Columbia's chief television engineer, is to be employed and it is stated that this will distribute the power evenly over the area to be served. The new aerial consists of 16 independent dipoles—8 for sound radiation and 8 for visual images. To assure maximum effi-

ciency during the winter, all antennas will be heated from the inside and thermostatically controlled so that ice cannot form on them. The antennas will be practically invisible from the street.

Auxiliary to the new transmitter are electrical transformers now being installed, which will supply 1,500,000 watts of power. Of this amount, the transmitter will use about 300,000 watts for sending out the powerful, high-definition picture signal.

Because of the very high voltages employed, operators will be protected by an elaborate system of safety devices. All doors to the transmitter room proper, as well as all panels over high-voltage equipment, will carry interlock switches to cut off power automatically when the doors or panels are opened.

A further precaution is the "shorting plug" arrangement, placed near the door leading behind the transmitter panel. When a man goes to work

behind the panel, he takes one of these plugs along, thereby disconnecting the circuit. Only when each man has returned and all plugs are in place will the circuit be completed. On the master control desk, a panel of 20 control lamps indicates the exact location of any operator working near high-voltage equipment. Forty additional control lamps indicate the operating condition of the various power units.

Installation is proving a difficult matter for it was found that the freight elevator—although it had been restrung with heavier cables and rebalanced with additional lead weights—was unable to lift the mammoth electric transformers for the transmitter. This necessitated the draining of thousands of pounds of oil from the transformers to lighten them. But now C.B.S. technicians are worrying about the fact that this oil must be especially filtered and all traces of moisture removed before it can be replaced.

The new transmitter will operate under the call letters, W2XAX, supplanting the low-power equipment which has been used for experimental purposes at Columbia's television laboratories in the C.B.S. Building at 485 Madison Avenue.

## MECHANICAL-OPTICAL RADIO GEAR

**I**T is interesting to note that the Scopphony receiver employs entirely separate apparatus for the reception of vision and sound signals.

### The Vision Receiver

Tuned radio frequency amplification is used for reception of the vision signals. A tuning control is dispensed with. Eight valves are used of which four are R.F. amplifiers and two are diodes for rectification and separation of synchronising impulses.

The output from the vision radio receiver is via a low impedance output valve and co-axial cable to the light control drive unit, which consists of video amplifier, oscillator R.F. amplifier and D.C. reinsertion valve.

(The R.F. amplifier valve is connected to the quartz crystal on the light control and is grid modulated by the video amplifier. The apparatus is so designed that the full 5 megacycles of the two sidebands are fed to the light control.

This is the valve arrangement at present used, though other alternatives are possible.

### The Sound Receiver

For the sound, six valves are employed utilising tuned radio frequency amplification at carrier frequency. This method was adopted in order to avoid constant retuning necessary in a receiver of the super-heterodyne type, which arises from frequency drift of its oscillator. Anode bend rectification is employed and is fed to two output valves which work the 10-in. loud-speaker. The sound receiver has very high fidelity in order to make full use of the high quality which is transmitted.

Ensure obtaining "Television and Short-wave World" regularly by placing an order with your newsagent.



It is always of interest to obtain first-hand information on television development in other countries and compare their results with our own efforts. Recently I had the privilege of visiting the television studio in Paris and examining all the apparatus.

For some considerable time the French Government have been testing various systems at the Eiffel Tower station and they have now finally decided on the equipment developed by The Materiel Telephonique Company.

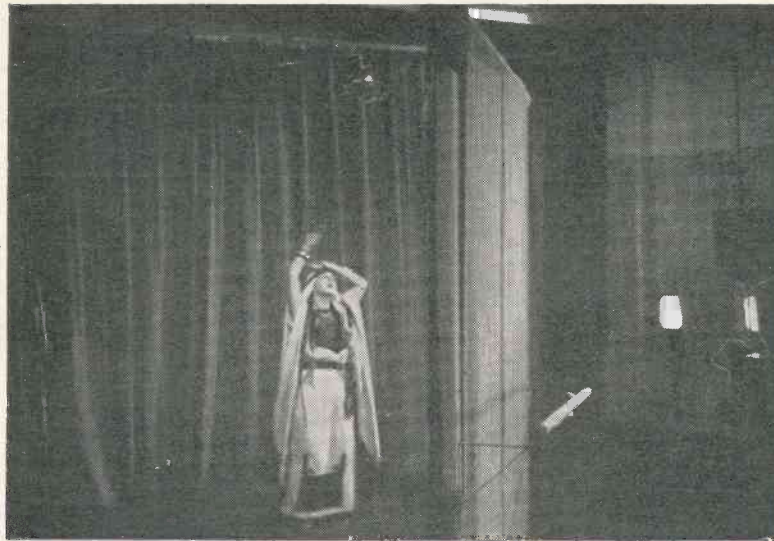

Dancer being televised in Paris television studio. The screen in the middle foreground of the picture is for the use of close-ups or announcers.

with respect to the synchronising pulses. This is kept constant at 30 per cent. of peak carrier.

The definition used is 455 lines interlaced at 50 frames per second. On the present radio transmitter the full band is not transmitted, but in new equipment which is now being constructed this will be remedied.

The output from the vision transmitter is fed by means of a balanced feeder to the Tower where a transformer is used so that coaxial cable can be used to carry the

## A VISIT TO THE EIFFEL TOWER TELEVISION STATION—By Our Special Representative

This company is associated with the Standard Telephones & Cables, Ltd., of London.

The Eiffel Tower station is working daily and transmitting programmes from the P.T.T. studio about a mile away. Only one room is used for the studio as there are difficulties in allocating sufficient space in the present building. (The studios are situated in the main Post Office building.

### One Camera Only

One camera is employed for all programmes and there are no film transmissions. The camera is of the same type as used by the B.B.C., and was obtained from this country. It is mounted on a "dolly" and the operator has to focus his camera either on the announcer or the artists as may be necessary. The lighting is similar to that used at Alexandra Palace. The photograph reproduced shows the studio during a transmission.

The control room is situated outside the studio which can be viewed through a plate glass window. The programme during the afternoon, when I was present, consisted of two juvenile acts and dancers. It was apparent that the use of only one camera severely limited both the pro-

gramme material and method of presentation. (This limitation was particularly noticeable during the dancing turn.

The signals are fed by coaxial cable to the main transmitting station built underground at the side of the base of the pylons of the Tower. (The transmitter comprises similar equipment to that at Alexandra Palace. The vision unit derives its frequency from thermal-frequency crystal control and by frequency doublers to the final stages; this is grid modulated and the peak power output is in the order of 30 kilowatts. Positive transmission is used, that is, peak white represents peak power output.

### The Sound Transmitter

The sound transmitter is a conversion of an old vision-transmitter which has been modified. This at present is situated in a separate room. In another room is the line termination and picture control gear. One of the racks contains a monitor and the engineers can switch from line or radio pick-up at will so that a direct check of transmitted picture quality can be made. Two other cathode-ray tubes are used, also in the control room, one for modulation depth, and the other for checking the D.C. level

power to the di-poles on the top of the Eiffel Tower.

(There are few, if any, receivers in use by private viewers. I witnessed reception in a viewing room provided by the French Post Office in a building near the studio. This viewing room is provided for the use of the public so that they may obtain an insight into television progress. I arrived there on "crisis" day, which may have accounted for the fact that only a few people were taking advantage of the facilities provided. Three receivers were demonstrated. Two of them were cathode-ray receivers of the direct type with screens approximately 10 in. by 8 in. The pictures were black and white, and were standard type receivers as manufactured by two large French concerns. The quality was definitely worse than that seen on the check receiver at the transmitter and was spoilt by intense phase distortion.

The third receiver was interesting in that it was a British-made cathode-ray projection type instrument giving a picture approximately 20 in. by 16 in. The screen was greenish in colour. It was on this that the picture quality could best be studied. Definition was definitely below that which is transmitted by the B.B.C., the camera technique also was poor.

# Television Digest

*Interesting Abstracts from the World's Television Literature*

## Colour Matching (Electronics, New York)

THE instrument described by this article was constructed to designate colour matches with high precision either by reflection or transmission methods.

A sensitive bridge circuit employing two R.C.A. photo-cells of the vacuum type was used and is shown

circuit of this nature. (These photo-cells have top-cap connections, the anode being brought out to the cap on the one tube, the cathode on the other tube. As indicated in the circuit, the grid cap of the amplifier tube connects only to the top-caps of the two photo-cells. Short top-cap connections to the three tubes, result in an extremely high resistance

double condensing lens and light balancing shadow vane are also contained in this compartment.

A description of the operations entailed in making a routine colour test or match should be of help in explaining the functions of the light valve and shadow vane in the lamp house.

With all switches in the "off" position the main power switch is put on and the apparatus given several minutes to heat up. (The balancing circuit knob is now turned into the "on" position and the meter needle centred on mid-scale. A reflector is placed in the back window trap. One of the colour filters is placed in the slide and the standard colour is placed in the front window trap. The light source is next switched on and with the calibrated light valve set at zero mid-scale the shadow vane in the lamp house is adjusted to bring the meter needle back to zero.

The standard is now replaced with the sample to be matched against it. If the meter needle deviates from zero it indicates a mis-match, plus or minus. Again the meter needle is brought to zero by an adjustment of the calibrated light valve or iris diaphragm. When this condition obtains the reading on the light valve scale is indicative of the percentage difference in the tonal range of the sample and standard as far as that particular band of the spectrum is concerned.

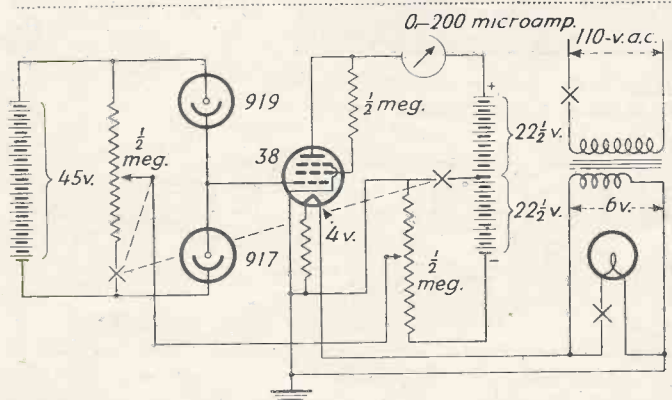

Fig. 1. Circuit arrangement of colour matching apparatus.

in Fig. 1. A voltage divider across the charging voltage of the photo-cells balances the system. By adjusting the voltage divider, the meter needle may be made to rest at mid-scale zero with no light on the tubes. Because the tubes are in

leakage path. Leakage may be further decreased by coating the bulbs with a non-hygroscopic wax. The windows of the photo-cells should be free from wax.

A bias voltage divider on the pentode compensates for differences in

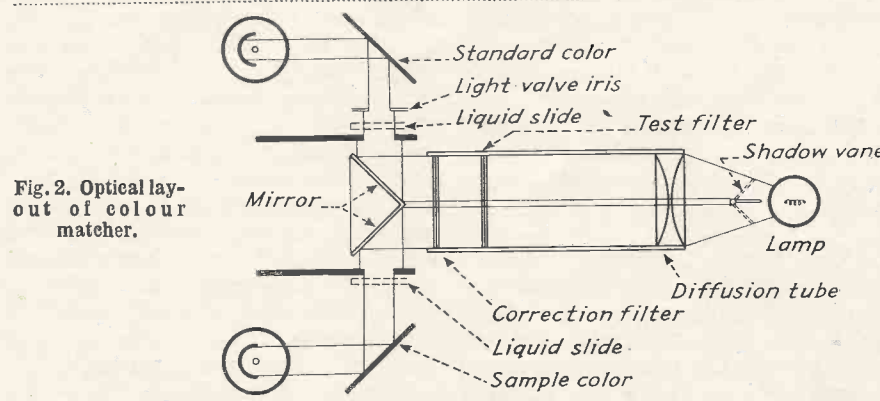

Fig. 2. Optical layout of colour matcher.

series and must pass the same current, a larger quantity of light imposed on one tube as compared to the other decreases or increases the mean total bias on the amplifier, a 38 pentode operating at 4 volts on the heater to increase stability.

The photo-cells, type 919 and 917, are especially sensitive in a balanced

photo-cell sensitivity by allowing shift of the grid-plate characteristics of the amplifier valve.

The lamp house is located some distance from the main body to insure stability by reducing thermal variations in circuits. It contains the light source, a Mazda lamp of the concentrated filament type. The

## Picture Sizes (Murphy News)

The ratio of picture width to height at the B.B.C. transmitter is 5 to 4. With this knowledge we can work out for any diameter the theoretical maximum dimensions of picture than can be accommodated, and columns 2 and 3 of the table give these dimensions for a number of sizes of screen diameter.

In practice, of course, the end of the tube is not flat and since the extreme corners of the picture seldom contain anything of very great interest, a certain amount may be sacrificed to increase picture size. The limits which we have set ourselves

(Continued in first col. of next page.)



# HOW THE PICTURE IS SYNCHRONISED

Since the whole success of television reproduction depends on the accuracy of synchronising, the circuit by which the pulse is applied to the scanning generator must be as carefully designed as any part of the receiver. In this and succeeding articles G. Parr describes the various forms of circuits used and the effect on the pulse.

If the chart of the wave-form of the E.M.I. transmission is examined (Fig. 1) two types of syn-

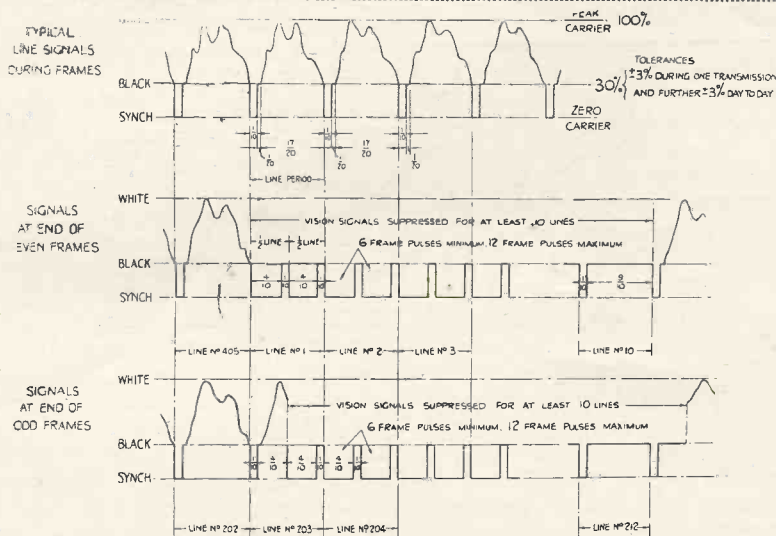

Fig. 1. Marconi-E.M.I. waveform.

chronising pulse will be seen. Between the line signals occurs the line sync. pulse, which is a short pause

## "TELEVISION DIGEST"

(Continued from preceding page)

are that the maximum sacrifice is that corresponding to 10 per cent. increase in picture dimensions. This is given in columns 4 and 5 below.

(1) Tube screen diameter	(2) Theoretical maximum picture width	(3) Theoretical maximum picture height	(4) Practical maximum picture width	(5) Practical maximum picture height
4"	3.1"	2.5"	3.4"	2.7"
5"	3.9"	3.1"	4.3"	3.4"
6"	4.7"	3.8"	5.2"	4.2"
7"	5.5"	4.4"	6.0"	4.8"
8"	6.3"	5.0"	6.9"	5.5"
9"	7.0"	5.6"	7.7"	6.2"
10"	7.8"	6.2"	8.6"	6.9"
11"	8.6"	6.9"	9.4"	7.6"
12"	9.4"	7.5"	10.3"	8.2"
13"	10.0"	8.0"	11.0"	8.8"
14"	10.9"	8.7"	12.0"	9.6"
15"	11.7"	9.4"	12.8"	10.0"

If the dimensions are exceeded, not only does this result in excessive distortion at the corners of the picture, due to bulb curvature, but also part of the picture will be actually cut off. The safest figure to take when assessing picture size is undoubtedly the true screen diameter so that a fair comparison can be made.

end of each frame is a composite one consisting of eight broader pulses, each of 40 microseconds duration with an interval between each. The duration of each line signal is 100 microseconds, including the time allotted to the pulse, and since the time occupied by each broad pulse is 50 microseconds, these will occur at intervals corresponding to half a line. For this reason they are usually referred to as "half-line pulses," and their object is to maintain the line scanning generator in step during the operation of the frame flyback.

If the half-line pulses were absent, the frame sync. pulse would consist of a long break in the transmission lasting for 400 microseconds. This would be sufficient to ensure the return of the beam at the end of the frame scan but during the return the line scanning would be out of control and would continue to traverse the screen at the natural frequency of the scanning circuit. This might be very different from the frequency of the standard pulses with the result that at the end of the frame flyback the lines would be badly out of synchronism and would require several

pulses before they settled down again to normal running.

This effect was sometimes noticeable in the early days of high-definition transmission before the present system was standardised, and was shown by a flapping of the top edge of the picture which occupied the first few lines of each frame.

Again referring to Fig. 1 it will be noticed that the pulses at the end of the odd and even frames are spaced differently, the odd frame ending at half a line and starting again with half a line, while the even frames have the last line completed and interpose a line pulse before the start of the lines of the new frame.

As is now well-known, this staggering of the pulses and line signals results in the interlacing of the lines in the frames and it is therefore of the utmost importance that the pulses are transmitted correctly to the scanning generator if the accuracy of the line spacing is to be maintained.

To do this, special precautions have to be taken in the design of the synchronising circuit, which has for its object the separation of the line from the picture pulses and their application, undistorted, to the line and frame scanning generators.

Before dealing with the methods by which the pulses are separated and amplified it is convenient to consider the value of the average pulse in volts and the most convenient points at which it may be led off to the scanning circuit.

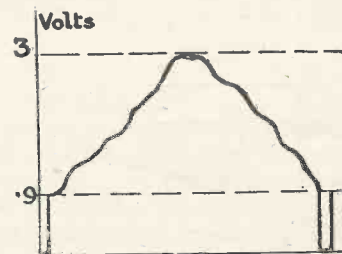

Fig. 2. Waveform applied to diode showing relative value of sync. pulse to signal.

**Value of Pulse**

To arrive at an approximate value of the amplitude of the pulse we can take first of all the voltage required at the output of the video amplifier to modulate the grid of the cathode-ray tube. The majority of electrostatic tubes require 20 volts to modulate the beam fully and magnetically focused ones require less.

This figure is not often attained in practice as the average "looker" does not operate the tube at full bril-

take off the sync. pulses as, after rectification of the carrier, a voltage of 30 per cent. of 1.5, or 0.5, would be available for synchronising. In practice, however, this figure is seldom reached, as the foregoing approximate calculations have not taken into account the curvature of the diode characteristic.

This can be seen from the diagram of Fig. 3, and it will be noted that with low values of input, such as we are working with, the output from the diode load is not linear in relation to the input. The result of this so

fore only suitable for supplying the sync. pulse voltage in cases where the output is reasonably high, unless a form of amplification is used before the pulse is applied to the scanning generator.

It is certainly possible to adjust the frequency of the scanning generator to such an accurate value that a sync. pulse of only a fraction of a volt is sufficient to trip the discharge valve, but in designing the sync. circuit the extremes of variation must be taken into account and it is preferable, particularly in the case of home constructed receivers, to have ample margin on which to work.

To amplify the value of the pulse we may use a separate valve connected to the output from the diode, but there is no need for the extravagance if the video amplifier stage is available. Most receiver circuits have the video stage directly coupled to the diode load, in order that the D.C. component may be passed through the amplifier\* and it is therefore just as convenient to take the pulse from the video amplifier circuit with the added gain introduced by the valve.

There are two points from which the connection may be taken—the cathode resistance or the anode load resistance. In the first case the level of the sync. pulse is still maintained in its correct relation to the rest of the signal owing to the direct connection between the diode load and the video valve, while in the anode load resistance it will be neces-

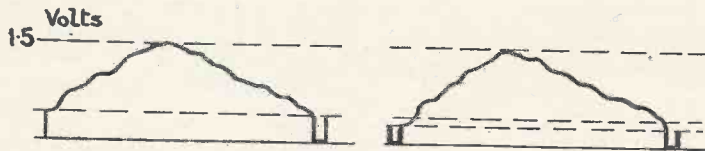

Figs. 4 and 4a. The signal at the output of the diode. (a) The same signal altered by diode characteristic.

liance on the white portion of the pictures and the input to the grid is usually reduced by the control. If one video amplifying stage is employed, the gain will be in the neighbourhood of 12-15, so we can estimate the input to the grid of the video amplifier by assuming an output of 20 volts peak value and dividing this by 12. This will give a peak value of approximately 1.5 volts on the grid.

If the efficiency of the diode detector is 50 per cent. this output will be given by an input of 3 volts peak, and we can then sketch the waveform of the signal applied to the diode detector in terms of voltage amplitude as in Fig. 2. The proportion of the sync. impulse to the total carrier amplitude is 30 per cent., so that we can draw a line at 0.3 times the height of the peak amplitude and mark this as the level of the sync. pulse.

It might be considered at first sight that the diode load resistance was the most convenient place from which to

far as the sync. signal is concerned will be to reduce its effective value to below the theoretical figure.

If the diode were linear throughout its working range, the output waveform across the load would be as shown in Fig. 4, which is half the amplitude of that in Fig. 2 (assuming 50 per cent. only of the rectified voltage appears across the load resistance). Due to the curvature of the characteristic, however, the output waveform will be more nearly that of Fig. 4a, in which the amplitude of the sync. pulse is reduced in relation to that of the signal.

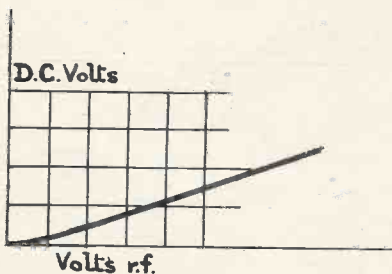
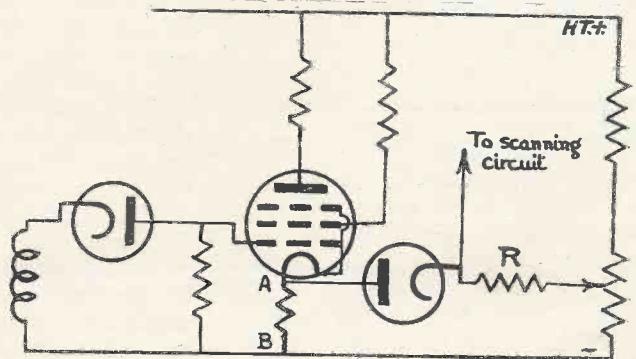

Fig. 3. Characteristic of diode showing the curvature which gives distortion at low inputs.

Fig. 5. Diode and video amplifier showing a method of separating the sync. pulse.



This reduction will be increased still further if any form of amplitude control is used in the receiver, as we have assumed so far that the full voltage of the video stage is required for modulating the tube, and, as said above, this is seldom the case.

The diode load resistance is there-

sary to interpose a condenser in the output to keep the H.T. from the valve in the scanning circuit. On the other hand the gain will be higher, and this is an important consideration.

\* See "T. & S.W.W." March, 1938, p. 157.  
(Continued on page 679)



# Telegossip

## A Causerie of Fact, Comment and Criticism

By L. Marsland Gander

WHEN the crisis had reached its most explosive stage and parks and commons were being turned at a feverish pace into a fair imitation of No Man's Land, the B.B.C. decided to close down its television service if war broke out. The ultra-short wave sound channel would in all probability have been retained for the transmission of news, official announcements, etc.

Why the television service should close immediately any more than theatres, cinemas and music-halls I do not know. Places of entertainment in wartime play an invaluable role in maintaining civilian morale and providing recreation for men of the fighting services. It is as well for those who have the interests of television at heart to realise that they have just escaped by a hair's breadth a staggering blow to their hopes.

### Importance of Short Waves

Another reflection that follows the lifting of the war clouds is that it has become a national necessity to set up a country-wide chain of ultra-short wave transmitters. Owing to the limited range of ultra-short waves foreign transmitters could not interfere with British broadcasts on these frequencies, nor could they easily overhear any information intended specifically for the home audience. This is one of the strongest arguments in favour of creating a national television service, for in no other way can the public be persuaded to buy ultra-short wave receivers on a big scale. And, of course, if only a handful of listeners have the equipment to receive ultra-short wave broadcasts the plan breaks down.

It is time the Government realised the importance of this point. The B.B.C. is relying on boosting the power of its long- and medium-wave transmitters in the belief that the local wipe out would compensate for any interference from distant sources. But in any case the service area would be greatly restricted and nothing jags the nerves of listeners more than constant niggling interference either by heterodynes or Morse signals.

### Deliveries

During those days of war threat

many girl employees at radio and television factories were "conscripted" for work of national importance such as the assembly of gas-masks. What time their male colleagues were set to digging trenches and refuges.

All of which means another hold-up in the supply of television sets to customers. It is delicious irony that after beseeching the public to buy sets for years without much success the manufacturers have found themselves unable to meet the demand immediately and are now having to ask customers to wait. It is all the more remarkable that this state of affairs should have followed immediately upon Radiolympia, held with the avowed object of persuading the public to buy television sets.

But the plain fact is that the makers were so uncertain of public response to their blandishments that they waited for orders before perfecting production plans.

However, I hear that within the next few weeks all production troubles will have been smoothed out in the industry and as a prelude there is the possibility of another big publicity campaign in which the B.B.C. will co-operate with the Radio Manufacturers' Association. B.B.C. sound wavelengths will be used for publicity purposes. Somebody has hit on the novel idea of eye-witness accounts of popular television products. Mr. John Snagge has already given a running commentary on "Picture Page" for Empire listeners, and Mr. Thomas Woodroffe, from a special booth in the studio, is to do the same for National listeners early in November.

### The New D.G.

It is a good augury for television that Mr. F. W. Ogilvie, the new Director General, has already shown his great personal interest in the B.B.C.'s newest branch. Not only did he inspect the television equipment at Radiolympia but he also paid a personal visit to Alexandra Palace, visited all departments and had an informal chat with practically every member of the staff.

When I met him at Broadcasting House a few days ago he told me that he had had a television set installed at his Hampstead home and was

watching the programmes on any night when he could spare the time from the duties of Director General.

I was invited recently to talk to the Television Society on the subject of B.B.C. programme improvements since the service started. Inveterate grousers may say that there is nothing to choose between the pictures of champion birds, beasts and fishes transmitted in the early days and third rate studio material to-day. I prefer to think of the progress from the time when the B.B.C. showed us how to repair a broken window to the recent Test matches; from the first crude adventures in television drama to "Libel," "Rush Hour," etc.

But it came as a rude shock to realise that in one respect there had been no progress. When I gave that talk a few days ago the B.B.C. was as badly off for studio accommodation as it was when the service started two years ago. Since then re-equipment of No. 2 studio has been completed and both studios were to be used together in the presentation of the play "Cyrano de Bergerac."

As regards the theatre conversion the plans are still all on paper. I understood last month that orders for the work and equipment had been placed. Yet it appears even now the B.B.C. has failed to sign on the dotted line and everything is held up. The delay is quite inexplicable after the official assurances that no more time was to be wasted.

Since the service began the only real and solid progress in the provision of extra facilities with substantial effect on programmes has been the purchase of the two complete mobile units. These vans are capable of extending programme time with an immense variety of interesting topical and sporting programmes. There is talk at Alexandra Palace of a whole fleet of these mobile units, at least half-a-dozen, and it may be that this is the solution of the whole programme problem.

The B.B.C. has come to a parting of the ways when it is necessary to decide whether to proceed without further delay on the projected extension of studio space or to provide more mobile units. The great snag with outside televising is, of course, the quality of picture.

(Continued in third col. of next page.)

# A NEW FILM TRANSMITTER FOR A.P.

EVER since the electronic system was exclusively adopted at Alexandra Palace, viewers have complained that the quality of the film transmission was not equal to that of direct transmissions. The reason for this is that films have always been transmitted by means of

(The optical compensating system used is of a type originally made some ten or twelve years ago for kinematograph projection, and known as the Mechau; it is not today used for that purpose in this country, owing to the difficulty of adapting it to sound reproducing

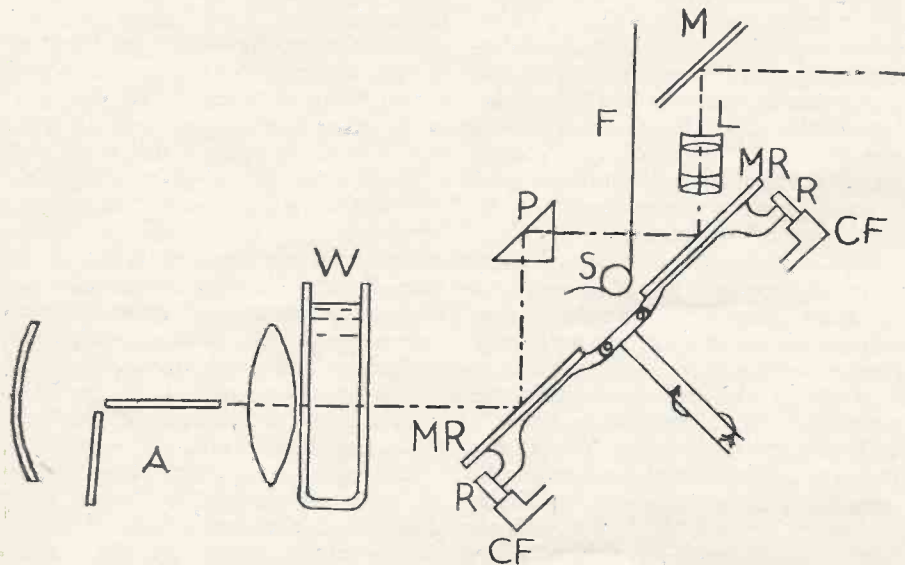

Schematic diagram of continuous-motion film projector.

an ordinary intermittent-motion film projector, used in conjunction with an Emitron; in order to provide the interlaced scanning, it has been necessary for the image to be projected upon the screen of the Emitron for only a very short space of time, the storage effect of the mosaic screen providing signals for the double traversal.

Many engineers have felt that this storage principle was not too satisfactory, and in a new transmitter installed at A.P. a few weeks ago, the film is moved continuously, and is imaged all the time upon the screen, there being no dark period. An official description of the new equipment—also of a new control room linking up the two studios, telecine, and O.B.—will be published next month, but the following is a description of the former by a TELEVISION AND SHORT-WAVE WORLD representative who was granted facilities for examining the equipment.

systems, but is apparently used on the Continent for television work by A.E.G.

In this mechanism, the film runs from a horizontal take-off, and is fed by a continuously moving sprocket through the gate. A system of oscillating and rotating mirrors which are interposed both between the illuminant and the film, and between the film and the objective lens, gives a stationary picture on the screen.

The principle of this optical system will be clearly seen from the sketch reproduced, which is however by no means to scale, and moreover shows an arc instead of an incandescent light source. The light of the arc *A* is focused through the water-cell *W* upon the lower part of the mirror ring *MR*; this comprises 64 pivoted mirrors, rotating on an inclined spindle, and each tilted by the rollers *R*, working on the cam face *CF*.

The light beam is reflected from

the lower mirror, which tilts to enable the beam to follow the film travel. After reflection from the prism *P*, the light is focused through the film *F*, fed continuously by the sprocket *S*, and upon the upper mirror of the ring *MR*, which is also oscillated during the rotation of the ring by the movement of the roller *R* on the cam face *CF*, in order that the picture may appear stationary on the screen. The image passes through the lens *L* and is again reflected from the mirror *M*, in the present case upon the screen of the Emitron.

It is difficult to say as yet that this new system has much improved film transmission; one still sees the unsightly grey blotches in the corners, and half-tone reproduction still compares unfavourably with direct transmissions. However, it is early to give a definite opinion as possibly with further experience improved results will be obtained.

## "TELEGOSSIP"

(Continued from preceding page)

I was at North Weald aerodrome when the B.B.C. televised Hurricane fighters in action. Bands of interference marred the pictures as received on televisors. Had viewers seen those beautiful streamline machines soaring like gulls and speeding in line abreast across the sky as I saw them on the windswept aerodrome they would have had a memorable thrill. Then poor lighting marred the pictures from the Motor Show at Earls Court. It was necessary to instal batteries of special lamps for the film *Première* from the Carlton.

The vans will work overtime at Christmas on a programme scheme vaguely described in official circles as "original and seasonable." A series of transmissions will come from the West End.

How many viewers have noted and wondered about the disappearance from the television programmes of announcer David Hofman? He has been transferred to Broadcasting House and I have heard his voice many times in the sound programmes. There is no immediate intention of filling his place at Alexandra Palace and in the meantime the two girls, Miss Jasmine Bligh and Miss Elizabeth Cowell are carrying on.



# TELEVISION TO REVOLUTIONISE KINEMATOGRAPHY!

## "RECENT ADVANCES IN ELECTRONICS AND THEIR APPLICATION TO KINEMATOGRAPHY"

By A. G. D. West, M.A., B.Sc., President of The British Kinematograph Society

A. G. D. West, Esq., M.A., B.Sc. (Baird Television Ltd.), the President of the British Kinematograph Society, opened the winter session by giving an address on October 20, on "Recent Advances in Electronics and their Application to Kinematography." Mr. West took as his theme, the subject of the increasing influence of electronic methods on the technique of the kinematograph industry and the following is an abstract of his address :

MR. WEST opened his address by expressing his thanks to the members of the Society for his election to the Presidency. After giving a technical summary with regard to the operation, manufacture and use of electron tubes, he indicated that as the electronic art was now progressing at such a rate it would not be many years before a complete and satisfactory electronic system could be used in the taking of moving pictures, the distribution throughout the country, and their reproduction on the screens of cinemas.

We define electronics, said Capt. West, as that branch of science which relates to the conduction of electricity through gases or *in vacuo*. Many large industries depend entirely on established and commercialised uses of electron tubes: such industries as those of radio broadcasting, radio broadcast reception, and world-wide communications, which would not exist without the electron tube.

The processes taking place in an electron tube in every case consist of three distinct stages:

1. The release of electrons from conductors into the tube.
2. The control of these free electrons as they move about inside the tube.
3. The making use of their movement and the energy which they represent in a specific way.

Their movement is subject to control in three ways:

1. By the presence of an electrostatic field of force.
2. By the presence of an electro-magnetic field of force.
3. Due to the presence and motion of other nearby electrons.

Finally, we can make use of their energy by methods such as the following:

1. By making them enter a conductor and charge it up, resulting in a flow of current from the tube.
2. By causing them to bombard something in the tube to heat it up.
3. By causing them to impact on a screen consisting of fluorescent material, giving rise to light.

The use of tubes employing thermionic emission, such as amplifying valves, and the use of tubes employing photo-electric emission, such as photo-electric cells, are very familiar and therefore I would like to draw attention to the special study of two other particular processes, namely, the secondary emission of elec-

trons, and the study of electron optics, which is concerned with the motion of electrons in travelling from their point of entering the tube, called the cathode, to their point of exit from the tube, called the anode. These two processes have, during the last few years, attained very considerable importance in electronic work.

Let us consider in more detail the three stages in operating the electron tube. So far the photo-electric cell is mainly known for the purpose of converting the variations of light passing through the sound track of the combined print into corresponding electrical variations which in turn operate the loudspeaker. But the photo-electric surface now plays an increasingly important part in converting the elements into which a picture may be divided into corresponding variations

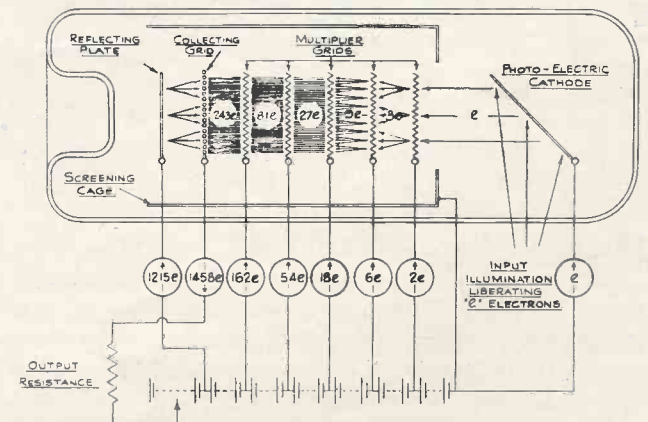

Fig. 1. Schematic diagram of action of Baird Multiple photo-electric cell. Arrows denote direction of electrons. Secondary emission multiplication per grid -3. Secondary emission multiplication per plate -6. Total gain 1,215 times.

of electrical current. The process of transmitting a picture by television involves the scanning of the picture or, in other words, the regular division of the picture into a definite number of elements which are dealt with in turn in accordance with some arbitrary rule.

### Secondary Emission

Now, taking the next important principle—that of secondary emission—it has been found that if a stream of electrons is allowed to bombard a metallic surface

## USING THE MULTIPLIER PRINCIPLE

having certain definite characteristics, each electron can be made to displace a definite number of electrons, depending on the type of surface which is used. This effect is having a growing amount of importance in overcoming some of the difficulties of electron tubes as, for example, the difficulty of lack of sensitivity of the average photo-electric cell.

The cold emission of electrons so far has not been made use of with advantage in developing electron tubes, but the use of electron tubes where the ionisation of gases is employed has made great strides in recent years, being used in new types of electric discharge lamps which are making great headway for illumination purposes where the question of economy is all important.

Now, coming to the control of the movement of free electrons inside the tube; the most important principle attracting our attention is that of electron optics. It has been found possible to study the movements of electrons by making a very complete analogy with the corresponding principles of geometrical optics. The movement of an electron under the influence of electromagnetic or electrostatic fields is defined in accordance with certain well specified and well-known laws. It is the study of electron optics which has enabled television engineers to make great progress in the cameras and picture reproducers which they now use.

### Fluorescence

As regards the uses to which the energy of the electrons can be put on arrival at the anode of the tube, I need only mention, Capt. West said, the phenomenon of fluorescence, whereby the impact of electrons on certain materials releases light which can be employed in building up a reproduced picture. The use of fluorescent materials of this nature at the present moment constitutes by far the most important of the methods employed for the reproduction of television pictures.

### Multiplier Photo-electric Cells

We are interested in making photo-electric cells with much greater intrinsic sensitivity, in other words, having greater efficiency in the conversion of light values into electrical currents. The maximum sensitivity available at the moment for the type of cell which can be used for this purpose, namely, the caesium cell, is about 50 microamperes per lumen. It is now possible to employ the principle of secondary emission to increase this value of sensitivity many thousands of times. If electrons from the photo-sensitive surface, before being led out of the tube, can be made to strike a surface which has secondary emitting qualities, then the electron current can be magnified many times, in some cases up to 10 times. If this process can be repeated, then it is possible to obtain much greater effective magnification.

Fig. 1 shows a multiplier photo-electric cell manufactured by Baird Television, Ltd., in which the electrons from the photo-sensitive surface are led to strike in succession a series of parallel wire grids. Each im-

portant results in the electron current being amplified by a factor of three. The total amplification of the electron current can be up to 10,000 times, using a reasonable operating voltage (say, 1,000 volts) but very much greater using a higher voltage.

A similar type of static multiplier cell has been developed by Zworykin of the Radio Corporation of America. In this case electrons are reflected successively by parallel surfaces of a special shape.

### Multiple Thermionic Valves

The obvious question now is, "Can such principles be adapted to give high amplification thermionic tubes?" and the answer is, "Yes." One of the first practical examples of such a tube is the Philips-Mullard secondary emission valve, (Type TSE4). The designers of this valve have formed their electrode system so that the stream of electrons is made to strike an auxili-

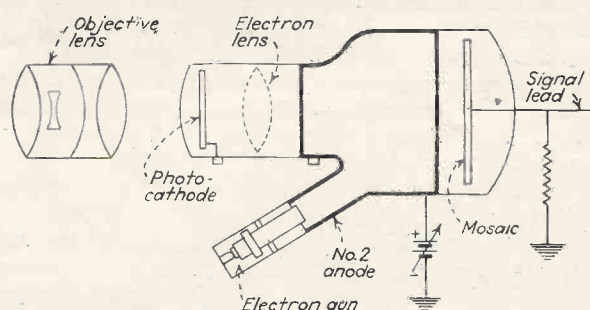

Fig. 2. Diagram of the image iconoscope or iconotron. The mosaic, bombarded by an electron image from the illuminated photocathode, emits secondary electrons, multiplying and storing the charge image. The mosaic is scanned, as in the usual iconoscope, by means of the beam from the electron gun.

ary secondary emitting surface before arriving at the anode. This single stage multiplying valve has on that account an effective gain of three times.

The practical use of such a valve is best demonstrated by comparing what was regarded two years ago as a radio amplifier for television of the highest efficiency with to-day's product of the same type. The earlier chassis had eight high efficiency pentode valves. The present chassis has three of the multiplier valves and provides more gain with greater stability and greater band width.

### Sensitivity

The problems of sensitivity in the pick-up (which specifies the lighting necessary on a scene to obtain a good picture free from disturbances) and of the brightness of the received picture, both depend primarily on the standard of definition selected. All the problems are rapidly increased by an increase in the number of lines chosen for the standard. As an example, if it is desired to double the number of lines for a given shape of picture, the number of picture elements is quadrupled and the performance of all the various pieces of equipment must be so many times improved.



## STORAGE ACTION

Note that in this normal scanning process at any given instant of time only one picture point is being dealt with and this prescribes a limiting factor to the degree of definition due to deficiencies in the devices which are used. As we shall see later, the problem has been partially solved by applying a principle, which is probably of greater general importance than any other recent development, namely, the storage of the action of light in each element of the picture, for the full period of time between two successive traversals of the scanning beam over that element. In other words, after an element has once been scanned, a process of storage takes place in that element until the scanning beam comes its way again so that by that time it has a much greater quantity of light to deal with. Thus the

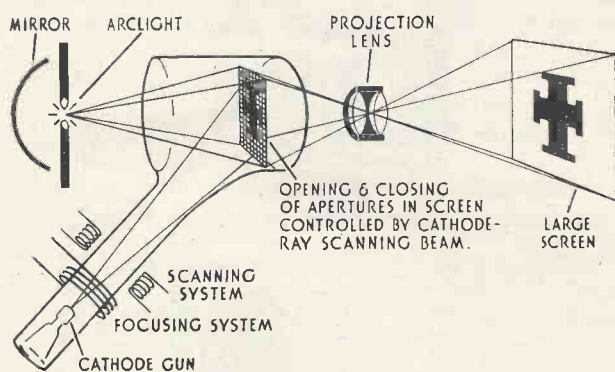

Fig. 3. Storage projection system.

use of the storage principle helps us very considerably in this connection with regard to sensitivity in the camera and brightness in the received picture.

### Storage Camera

I want now to explain a device which goes a long way to providing a successful means of converting picture scenes under all conditions of lighting into their electrical counterpart. In other words—the kinematograph camera of the future.

The simple general principle of an electronic device which can act as a camera for the transmission of pictures, can be regarded as a bank of photo-electric cells in number the same as the number of picture elements into which the scene to be transmitted is divided up.

It is possible to visualise such an arrangement whereby an image of the scene is focused by a lens on to such a bank of cells, the output from each individual cell being connected by some commutator device to the electrical transmission system. Thus, the scanning of the picture is carried out in any predetermined manner by taking the response from each cell in turn, such a response being exactly in accordance with the value of light projected on it from the original scene. Many devices of this nature have been tried and they have in general all failed to deal satisfactorily with the transmission (on a high-definition basis) of the ordinary scenes encountered in practice, on account of the lack of sensitivity of the photo-electric cell.

The solution of the problem has been found in applying the principle of storage to such a device. If this is done the light received on any particular cell throughout a given time period gives an electrical output which can be hundreds or even thousands of times more than the output given by the instantaneous electron current from the cell element when it is in operation only for the short period of time corresponding to the moment of scanning.

A great deal of the work in bringing a device of this nature into a practical form was done by Zworykin for the Radio Corporation of America. He named it the Iconoscope, and tubes having a similar fundamental principle were independently developed by Electric & Musical Industries in this country under the Trade Mark "Emitron" and are used by the B.B.C. at the Alexandra Palace for the transmission of television.

The principle of operation of the Iconoscope and Emitron is as follows: The image of the scene is projected by the lens on to a mosaic formed with separate minute insulated photo-electric elements. The emission of electrons continues from each particle of the mosaic throughout a complete period of scanning, say, one-twenty-fifth of a second, during which time each element builds up charges until such time as the elements are discharged by the scanning cathode-ray beam which comes from the cathode gun at the base of the tube.

The act of discharging each element provides an electric potential varying in accordance with the lights and shades of the scene projected on to the mosaic, at the metallic backing plate of the mosaic, and this is used to control a thermionic amplifier which modulates the television radio transmission.

A later form of tube of this nature employs in addition to the storage principle the principle of an electron converter. The optical image is focused on to a transparent photo-sensitive surface and an electron image from that surface is formed on the storage mosaic which is then scanned off as in the original Iconoscope. This form of camera may have a sensitivity up to ten times greater than that of the original form.

### Cathode-ray Tube as Reproducer

Turning now to the question of reproducing the picture: We have seen how a scan can be reproduced on the screen of a cathode-ray tube. It needs little further imagination to appreciate that by controlling the intensity of the cathode-ray beam in the tube or, in other words, the light value of the fluorescent spot, in accordance with the scanning currents developed by the television camera as it scans the light and shade parts of the subject, the picture can be reproduced on the screen of a tube.

### Large-screen Pictures

Our next problem is to take such a picture and reproduce it in a form suitable for showing in a theatre, where the essentials are size and brightness. Tubes for direct vision are controlled in size by the limitations of glass technique and bulk. The largest tube made in this country is a Baird with a diameter of 20 in.

## PROJECTION POSSIBILITIES

and as the pressure on the end is over two tons, the mind naturally turns towards the development of a small tube and the possibility of producing on its screen an intensely bright picture which can be used for projection by a lens on to a large theatre screen.

### Colour and Brightness of Tubes

Recent researches on the subject of fluorescent screens for cathode-ray tubes have been devoted in general to two things:

1. The production of light of any colour.
2. The attainment of much greater brightness.

There is a modern type of cathode-ray tube which is used for projecting television images on to a large screen and it is fairly clear, as there are at the moment no vital stumbling blocks apparent, that results will eventually be achieved which will not suffer as regards brightness by comparison with the normal cinema projection. The problems of cost and serviceability are problems which normally arise in developing equipment of this nature and need not necessarily be taken into consideration at this moment.

### Storage or Relay Projection Tubes

One of the limitations in this method is to be found in that the contribution of any particular element of the picture is only available for that minute part of time when it is being scanned. Our eventual hopes for the future are undoubtedly centred in obtaining some device which will introduce a storage or relay effect into the equipment. The suggestion of this general idea is also due to Zworykin, who has specified a receiving tube having a screen which consists of a large number of light flaps, there being one flap for each element of the picture.

A cathode-ray beam opens or closes these flaps in accordance with the vision signals received. The tube is thus not in itself a means of producing light but is a form of relay or, in simpler terms, a continuously changing lantern slide with which can be used an intense exterior source of illumination for projecting the picture thus formed on to the large screen of a theatre.

A special form of this principle has been suggested by Baird whereby each little element of the screen consists of a polarised light cell, the transmission of light through which is controlled by a cathode-ray beam modulated from the received vision signals.

### Application of Electronics to Kinematography

Let us now consider each part of our present technical system and see how electronics comes into it.

First for the recording and reproducing of sound, the thermionic valve rules in this domain with the assistance of the photo-electric tube.

### The Picture

For the picture in its progress through the camera, processing, printing and projection stages, even though a fixed technique exists which has little relation to the electronic art, I can see many minor uses for electronic

methods which would be of great assistance in saving costs of production and providing a more uniform product. An interesting example of research is taking place in studying the grain size of various emulsions and the effect on grain of the processes to which the emulsions are subjected. This has been done very effectively by means of a recording microscope using a photo-electric cell, thus making it possible to give a reasonably true measurement of the grain size and of the distribution of different sizes of grain. (The use of photo-electric methods of light measurement is by no means universal amongst cameramen, but I believe that if scientific methods were adopted in this connec-

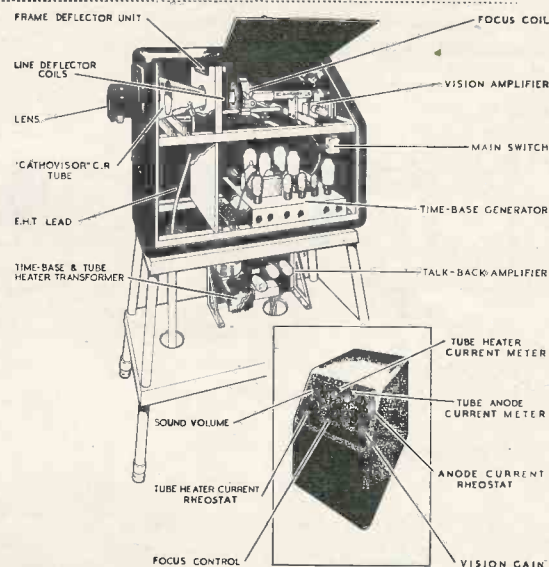

Fig. 4. Latest type of Baird cathode-ray tube projector for the cinema.

tion and if film printers were available with an automatic photo-electric control of the printer light (which could be used in all cases except where special effects are designed) then there would be much saving of time spent in the process of estimating printer exposures, and much greater uniformity achieved throughout prints distributed for projection.

My paper, however, is not directed so much to the immediate future but rather to studying the general trend over a long period of time. Let us see if we cannot, from the information available and the state of technique at the moment, and with a perfectly detached point of view, summarise a completely electronic system for kinema entertainment and study its possibilities from the point of view of technical perfection.

### Existing Equipment and its Capabilities

For this purpose we have the following general types of equipment available at the moment:

1. A camera which can be used under reasonable conditions of lighting. It has certain faults such as small depth of focus, and the presence of certain shadow effects which occasionally mar the picture, and insufficient detail for our purpose and also possibly a limited contrast range.



2. A method either by means of a short-wave radio relay or a cable connection of limited range, whereby the pictures provided by the camera, used either under fixed studio conditions or when rambling around for picking up news and interest items, are linked to a central distribution system in a manner which, though often successful, for the time being cannot be regarded as showing 100 per cent. reliability and quality.
3. A radio distribution system which though thoroughly effective as far as it goes, has a very limited range, say, only twenty miles or even less, where reception can be guaranteed free from interference. As an alternative we can visualise a high definition underground cable distribution system which can have a reasonable range but the setting up of which involves the expenditure of a very large sum of money.
4. A receiving and projection system which provides a screen illumination only a quarter or even less of what the average cinema requires and which uses equipment whose life and reliability have still to be proved.
5. A complete sound pick-up and reproducing system which can provide anything in quality and range that is demanded of it.

Thus we have in a completely electronic system in

general, at the moment, and as far as the picture part is concerned, nothing to compare technically with what the present established system of cameras, negatives, prints and high illumination projectors provides.

But, fortunately, research does not stand still. The remedies for all the above-mentioned deficiencies are in their fundamentals envisaged not only by the research theorist but by the practical scientist—a camera giving a clear picture with sufficient definition, a system of satisfactory distribution of the picture to all parts of the country, a projection result indistinguishable from that given in the best West End house.

But the solutions of these problems (although I have hinted at some of them) are not just round the corner. Still much research work is to be done, followed by sound engineering development to arrive at a product (as we shall do in the course of the next few years) which is satisfactory to the producer, the exhibitor and, most important, the patron. Thus it is reasonably safe to predict that all the processes of taking pictures and of distributing them to large audiences which go to build up the present motion picture industry are likely to be revolutionised by the electronic method, which though now only in its early stages will undoubtedly in time provide, by less cumbersome methods, all the entertainment and education and interest required by the great cinema-going public.

## "HOW THE PICTURE IS SYNCHRONISED"

(Continued from page 672)

Taking first the cathode load resistance, the sync. pulse is taken from the points marked A, B in Fig. 5. The polarity of the pulse will depend on the method of operating the video amplifier. In one method, which has been previously described,\* the bias on the amplifier is nearly zero when no signal is applied to the grid and the signal increases the bias in the negative sense. The sync. pulse will therefore cause a reduction in anode current corresponding to an increase in bias, and this reduction causes a voltage drop in the cathode resistance.

It should be noted that the cathode resistance in this form of circuit is not a bias resistance in the usual sense, but is for the purpose of providing sufficient voltage drop with change of anode current in the video valve.

As the picture signal causes an increase of bias on the grid and a further reduction in anode current, means must be provided for separating the voltage variation due to the sync. signal from that of the picture signal. This is done by inserting a second diode with its anode connected

to the cathode resistance as shown in Fig. 5. The cathode of this diode is biased by being connected to a potential divider across the main H.T. supply. The action is then as follows:

Suppose the diode cathode is biased negatively to about 20 volts, then no current will flow in it until the anode potential exceeds this value. The potential of the diode anode is that of the end of the cathode resistance in the video stage and this is adjusted so that the voltage drop is sufficient to pass current through the diode when the sync. signal is applied to the grid. When the picture signal arrives the anode current of the video stage falls still further and the voltage drop in the cathode resistance is no longer sufficient to pass current through the diode against the bias on the cathode.

The diode is therefore only conducting during the sync. pulse, and the pulses appear across the resistance R in the diode circuit, whence they may be transferred to the scanning generator.

This is one of the simplest and most satisfactory methods of separating the sync. pulse from the signal and is used in commercial receivers.

A further development of the circuit will be explained in the next article.

## Zeitschrift der Fernseh A.G.

A publication has been issued by the "Fernseh Aktiengesellschaft" (Television Co.) of Berlin, and gives information on the research work and general progress of the company. The copy received is numbered Part I and it is understood that further editions will be published from time to time. It is intended to give in each issue a review of the progress made in television by this company. We were indebted to this publication for the information on the Fernseh film transmitter published in last month's issue.

## The Radio Amateur Callbook

The new edition of the Amateur Callbook is now available from F. L. Postlethwaite, G5KA, 47 Kinfauns Road, Goodmayes, Ilford, Essex. This issue, which is right up to date and excludes the old O.E. stations, has most of the British amateurs down to G3P. The price of this callbook is 6s. per copy, post free.

G5KA also supplies a large number of handbooks written specifically for amateurs including "The Radio Amateurs' Handbook" price 5s. 6d. post free, published by the A.R.R.L., the "Radio Handbook" price 7s., which includes every aspect of short-wave radio, the "Radio" Antenna Handbook price 3s. 6d. post free, and many others.

\* See "T. & S.W.W." April, 1938, p. 214.

# RECENT TELEVISION DEVELOPMENTS

## A RECORD OF PATENTS AND PROGRESS *Specially Compiled for this Journal*

Patentees : F. A. Lindemann :: N. V. Philips Gloeilampenfabrieken :: Marconi's Wireless Telegraph Co., Ltd. :: V. Zeitline, A. Zeitline, and V. Kliatchko :: E. W. Bull :: Baird Television, Ltd., and P. W. Willans :: Radio-Akt. D. S. Loewe

### Cathode-ray Transmitters (Patent No. 487,940.)

THE picture to be televised is projected through a lens L and a transparent anode A to the near face of a photo-sensitive screen S. This consists of a layer of small photo-electric particles deposited on

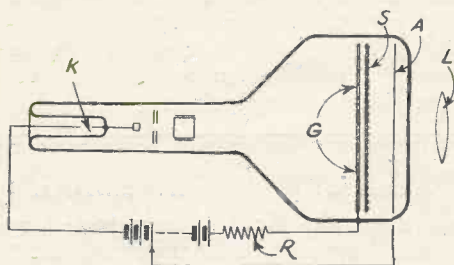

Pick-up tube Patent No. 487,940

a thin sheet of soda glass. The usual electric "charge" image is formed by the action of the light, and the lines of force from each charge pass through the glass sheet on to its rear surface, which directly faces the cathode K of the tube, so that it can receive the scanning stream. A "mesh" grid G is placed at a distance of about one millimetre from the screen S.

The picture "charges" are stated to act upon the electron stream in much the same way as the control grid of an ordinary valve, except that in this instance the grid G collects the electrons and uses them to produce a signalling current in the resistance R.

An advantage is that the screen S is arranged at right angles both to the received light and to the scanning stream, instead of being inclined to both as in the Iconoscope.—*F. A. Lindemann.*

### Magnetic Focusing

(Patent No. 487,998.)

Instead of using external coils to control the electron stream, a permanent magnet made of an alloy which is capable of standing a high

temperature without losing its magnetism, is permanently mounted inside the cathode-ray tube.

As shown in the figure, the magnet consists of a short steel-alloy cylinder M and two perforated end-plates P, P1. The main flux passes from one end-plate to the other, and then

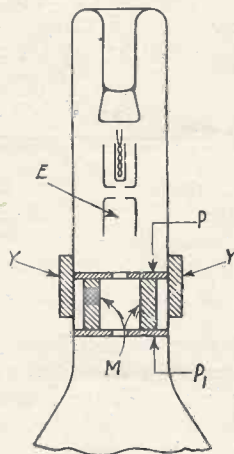

Magnetically-focused tube.  
Patent No. 487,998.

axially along the tube. To control the intensity of the field, an external yoke or shunt Y is moved over the end-plates, the field being weakest the more nearly the yoke closes the gap between the two plates.

The electron stream passes through the two central apertures to come under the influence of the field. The plate P may also be given a biasing voltage, in order to create an electrostatic control field between it and the nearest electrode E, in addition to the magnetic control.—*N. V. Philips Gloeilampenfabrieken.*

### Producing "Trick" Effects

(Patent No. 488,268.)

In the future development of television, it may be useful to be able to "manipulate" the picture in certain of the ways already practised in cinema films. For instance, it may be desired to produce "ghost" effects by superposing one picture on another, or to dissolve one scene into

another, or to insert advertising matter whilst the programme is in progress, and without disturbing the actors in the studio.

These and other effects are made possible by a method in which several different pictures, or selected "scanning areas," are fed into the same transmission channel, and are then combined to produce the particular "pattern" or composition required on the viewing-screen.—*Marconi's Wireless Telegraph Co., Ltd.*

### Electrostatic Focusing

(Patent No. 488,416.)

To secure uniform focusing of the electron stream of a cathode-ray tube, a succession of apertured discs are mounted between the cathode and the screen. These are arranged in two series, in one of which the apertures increase gradually from left to right, whilst in the other the apertures gradually decrease in the same direction.

The discs are interlaced one with the other, those forming one series being strapped together and given the same biasing-voltage, whilst those of the other series are similarly strapped together and given a different bias. The result is that the electron stream is uniformly refracted throughout the whole of its cross-section, so that all the electrons are brought to a focus at one and the same point on the screen.—*V. Zeitline, A. Zeitline and V. Kliatchko.*

### Safeguarding the Screen

(Patent No. 488,655.)

If the electron stream of a cathode-ray tube is allowed to form on the fluorescent screen before the scanning-voltages are applied to set it in motion, it is likely to damage the sensitive coating of the screen.

To prevent this from happening, when the cathode-ray tube is first switched on, the high-tension supply to the accelerator electrode of the tube is made to pass through a diode valve. The latter is biased in order

The information and illustrations on this page are given with permission of the Controller of H.M. Stationery Office.



to delay the building-up of the accelerating voltage until after the time-base circuit has come into operation on the deflecting plates of the C.R. tube. The scanning spot is therefore moving rapidly over the screen as soon as it is formed, so that there can be no risk of burning.—*E. W. Bull.*

**Time-base Circuits**

(Patent No. 489,102.)

Both "line" and "frame" synchronising impulses are applied from a terminal T, Fig. 1, through a delay network D to a common amplifier A. They are also fed simultaneously to the "line" saw-toothed oscillator L, where the comparatively slow "framing" impulses have no effect, but the more rapid "line" impulses set the line oscillator into action.

During the flyback stroke of each scanning line, a sharp impulse is fed back from L, as shown by the arrow, to the amplifier A and arrives

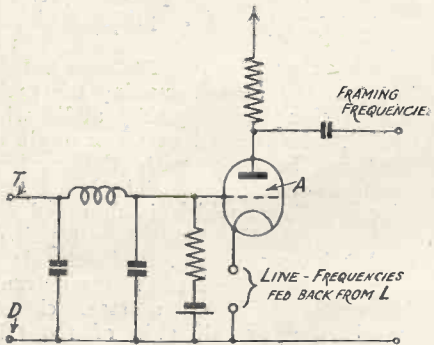
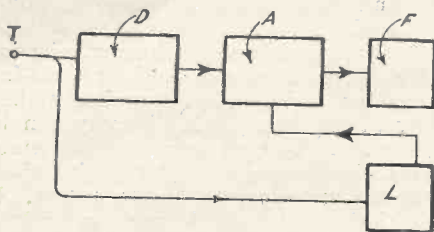

Line base circuits Patent No. 489,102

there in time to block the passage of the line-frequencies as they arrive from the delay circuit D.

Accordingly the line frequencies cannot get through to the "frame" saw-toothed oscillator F, though this does, of course, respond to the framing impulses passed through from A. Both sets of impulses are therefore confined to their proper channels. The circuit arrangement of the amplifier A is shown separately in Fig. 1a.—*Baird Television, Ltd.*, and *P. W. Willans.*

**Television Transmitters**

(Patent No. 489,422.)

In the ordinary type of cathode-ray transmitter, the picture is focused on to a mosaic screen, where it forms an electron image, which is then scanned by a moving beam of electrons.

According to the invention, the mosaic screen is mounted in a tube where it is exposed to the steady emission of electrons from a photoelectric cathode located at the opposite end of the tube. There is no gun and no rapidly-traversed stream of electrons, the scanning action being performed by a rapidly-moving ray of light, projected from a rotating disc fitted with spiral apertures.

The action of the light on the mosaic screen develops signalling currents which correspond to a reversed picture, the strongest currents representing dark portions and the weakest currents the high-lights of the original scene.—*Radio-Akt. D. S. Loewe.*

**Other Television Patents**

(Patent No. 481,865.)

Tube in which the electrons liberated from a photo-sensitive screen are projected on to a fluorescent screen set at right-angles to the first screen.—*N. V. Philips Gloeilampen-fabrieken.*

(Patent No. 481,944.)

Means for preventing leakage fields of force from distorting the picture produced by a cathode-ray receiver.—*E. Michaelis.*

(Patent No. 482,007.)

Cathode-ray receiver in which the return stroke of the scanning spot is extinguished.—*Farnsworth Television Inc.*

(Patent No. 482,725.)

Producing saw-toothed oscillations for scanning from a relaxation valve arranged in the diagonal of a Wheatstone Bridge.—*Cie Pour La Fabrication des Compteurs, etc.*

(Patent No. 483,348.)

Circuit for separating synchronising impulses from the picture signals in a television receiver.—*The General Electric Co., Ltd.*, and *G. W. Edwards.*

(Patent No. 483,622.)

Two-way television system which can also be used for the one-way transmission of higher-grade pictures.—*Marconi's Wireless Telegraph Co., Ltd.*

(Patent No. 483,650.)

Arrangement of the magnetic deflecting coils used in a cathode-ray tube.—*A. D. Blumlein.*

(Patent No. 487,501.)

Method of transmitting sound and picture signals, from point to point, partly through a cable and partly through the ether.—*Fernseh Akt.*

(Patent No. 487,833.)

Mounting the electrodes of a cathode-ray television transmitter so as to avoid relative or "microphonic" movement.—*H. Miller.*

(Patent No. 487,974.)

Method of mounting, spacing, and aligning the electrodes of a cathode-ray tube by means of insulating washers and flanges.—*The General Electric Co., Ltd.*, *J. E. B. Jacob*, *L. C. Jesty* and *G. W. Seager.*

(Patent No. 488,221.)

Rotating disc with two or more spiral turns of lenses for high-definition interlaced scanning.—*Radio-Akt. D. S. Loewe.*

(Patent No. 489,028.)

Electrode arrangement for the "gun" of a cathode-ray tube designed to increase the sensitivity of grid control.—*Radio Akt. D. S. Loewe.*

(Patent No. 489,199.)

Television transmitter of the image-dissector type in which the part of the scanning stream that is not absorbed on the sensitive screen is returned and made to do useful work.—*P. T. Farnsworth.*

(Patent No. 489,231.)

Separating circuit for the line and frame scanning impulses in which irregular operation due to the effect of adjacent impulses on each other is avoided.—*Electric and Musical Industries, Ltd.*, and *C. L. Fawcett.*

(Patent No. 489,428.)

Cathode-ray tube in which the electron stream is reflected, as from a mirror, by a "lens" system of electrodes.—*F. H. Nicoll.*

**The T.I.G.B.**

We have received from the Technological Institute of Great Britain a souvenir booklet on the coming of age (1917-1938) of this institute. The souvenir which will be sent post free on request, contains a large number of congratulatory messages from editors of technical publications and also from home and overseas students who have gained successes in various spheres as a result of tuition given by the T.I.G.B. The address is Temple Bar House, London, E.C.4.

The information and illustrations on this page are given with permission of the Controller of H.M. Stationery Office.